



GA-180 Gas Detector

Operation and Maintenance Manual

The information contained in this manual was current at the time of printing. The most current versions of all Hydro Instruments manuals can be found on our website: www.hydroinstruments.com

GA-180 Gas Detector Operation Manual

Table of Contents

I. Installation	
A. Monitor Installation	3
B. Sensor Installation.....	3
C. Battery Backup Installation.....	4
II. Operation	
A. Navigating the Controller.....	9
B. Operating Screens and Settings	9
C. Configuring a Sensor Channel	10
D. Installing and Configuring Temperature	16
E. Alarms and Outputs	16
F. Modbus Communication.....	20
G. Response Checks (Bump Testing)	20
H. Data Logger	21
III. Troubleshooting	
A. Installation Check	22
B. Symptoms, Likely Causes, and Suggested Responses.....	22
C. Explanation of Responses	23

Figures

1a. Sensor Installation (heavy gases)	3
1b. Sensor Installation (light gases)	3
2. Remove Calibration Cap	4
3. Wiring Diagram (inside of door).....	5
4. GA-180 Controller Electronics	6
5. Pinout Diagrams for MB108 and MB123	7
6. Pinout Diagrams for MB122, MB141, and MB101	8
7. Calibration Cap	12
8. Sensor and Calibration Kit	12
9. GA-180 Operating Screens	13
10. GA-180 Configuration Screens	14
11. GA-180 Modbus Configuration and Node Enable Screens.....	15
12. External Alarm Light and Horn.....	19
13. Bump Testing (Chlorine Gas Example)	20

Tables

1. Example Controller Configurations	6
2. Standard Ranges For Hydro Instruments Gas Sensors.....	11
3. Relay Options for Common Relays (33 & 34).....	17
4. Relay Options for Sensor Relays (1-32)	17

I. INSTALLATION AND OPERATION

A. Monitor Installation

All monitors are able to accept either 120 VAC or 240 VAC single phase power at 50-60 Hz. When connecting A/C power it is imperative that the power source is well grounded. Improper grounding will disrupt proper operation of the unit.

Warning: Ensure source power is disconnected from main power, prior to making the instrument connection.

Monitors are NEMA 4X rated and should be installed at/near eye level and protected from exposure to direct sunlight and rain. The monitor should be installed near, but outside of the chemical storage room it is monitoring (see Figure 1a and 1b). Four $\frac{5}{16}$ " DIA through holes are provided on the enclosure for mounting the monitor against the wall.

FIGURE 1a

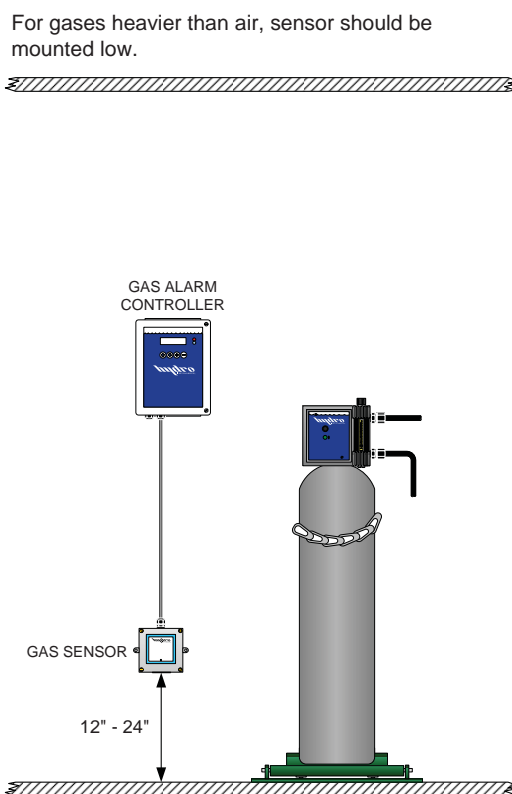
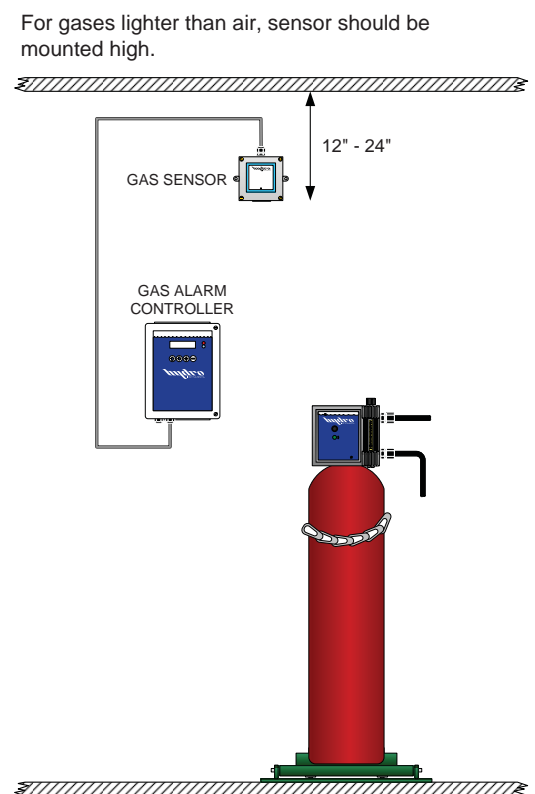

FIGURE 1b



B. Sensor Installation

Refer to Figures 1a and 1b for more information.

1. Determine a suitable mounting location. For monitoring gases heavier than air, the sensor should be placed approximately 12-24 inches from the floor. For gases lighter than air, the sensor should be placed 12-24 inches from the ceiling. Do not place sensor in any location where it could become wet. This will damage the sensor.
2. Attach the enclosure to the wall using two $\frac{1}{4}$ "-20 mounting screws (recommended).
3. Remove sensor calibration cap. Store this cap in a known location as it is necessary for calibration when using a span gas. See Figure 2.

4. If necessary, open the sensor enclosure front cover and reconnect the signal wires. Connect Red to Red and Black to Black on the terminal strip inside the sensor enclosure. Replace enclosure front cover and be sure to check that the gasket is evenly sealed around the enclosure. Also tighten the liquid tight fitting.
5. If necessary, connect the signal wire to the appropriate terminals. Refer to Table 1 and Figure 4 so that you can connect the sensor to the right channel. The black wire will connect to AI1 or AI2 and the red wire will connect to V+ depending on the required channel number.
6. Connect GA-180 main power, allow sensor to stabilize.
7. Configure the sensor channel. See section II.C.
8. Perform a bump test on all sensors installed on the monitor. Confirm sensor has appropriate response to the test gas.

FIGURE 2

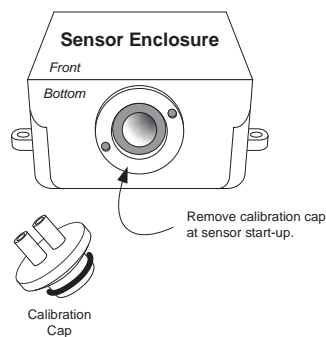

C. Battery Backup Installation

1. Disconnect A/C power before beginning this procedure.
2. Insert the battery into the enclosure by removing the surface protection tape and placing the Velcro strips on the enclosure back plate. The battery should be installed so that the leads are facing up.
3. Identify the positive (+) and negative (-) leads on the battery. Remove the plastic protectors on the battery leads and connect the positive lead of the battery to the “BAT +” terminal on the battery backup board (MB101). Connect the negative lead of the battery to the “BAT -” terminal on the battery backup board (MB101).
4. Ensure that the appropriate 24 VDC from the power supply is connected to the appropriate PS + and PS- terminal. For units with battery backup, the DC power must go into these terminals for proper operation and detection of A/C power failure.
5. If necessary, enable battery backup on relevant sensor channels. Use the screen tree (Figure 11) to access the relevant screens. Cycle the power to save the enabled battery backup setting.

Note: Battery 1 will need to be enabled to back up sensors 1-4, Battery 2 will need to be enabled to back up sensors 5-8, Battery 3 will need to be enabled to back up sensors 9-12, and Battery 4 will need to be enabled to backup sensors 13-16. For example, if a system is ordered with 8 sensors then two batteries will need to be installed (into their respective enclosures). Battery 1 and Battery 2 will need to be enabled. If a unit was purchased at the factory to have battery backup this will have already been done.

FIGURE 3: Wiring Diagram (inside of door)

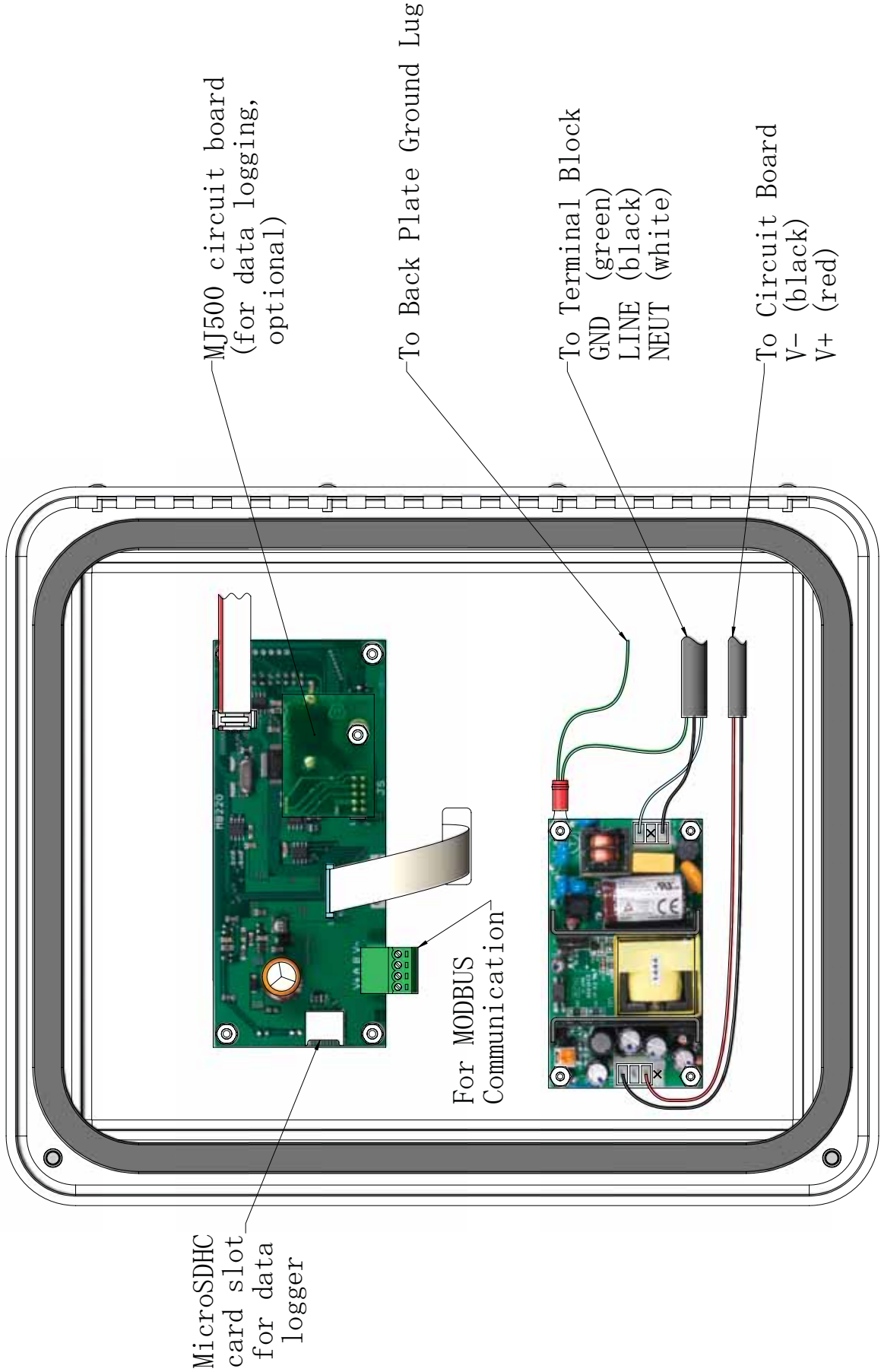

FIGURE 4: GA-180 Controller Electronics

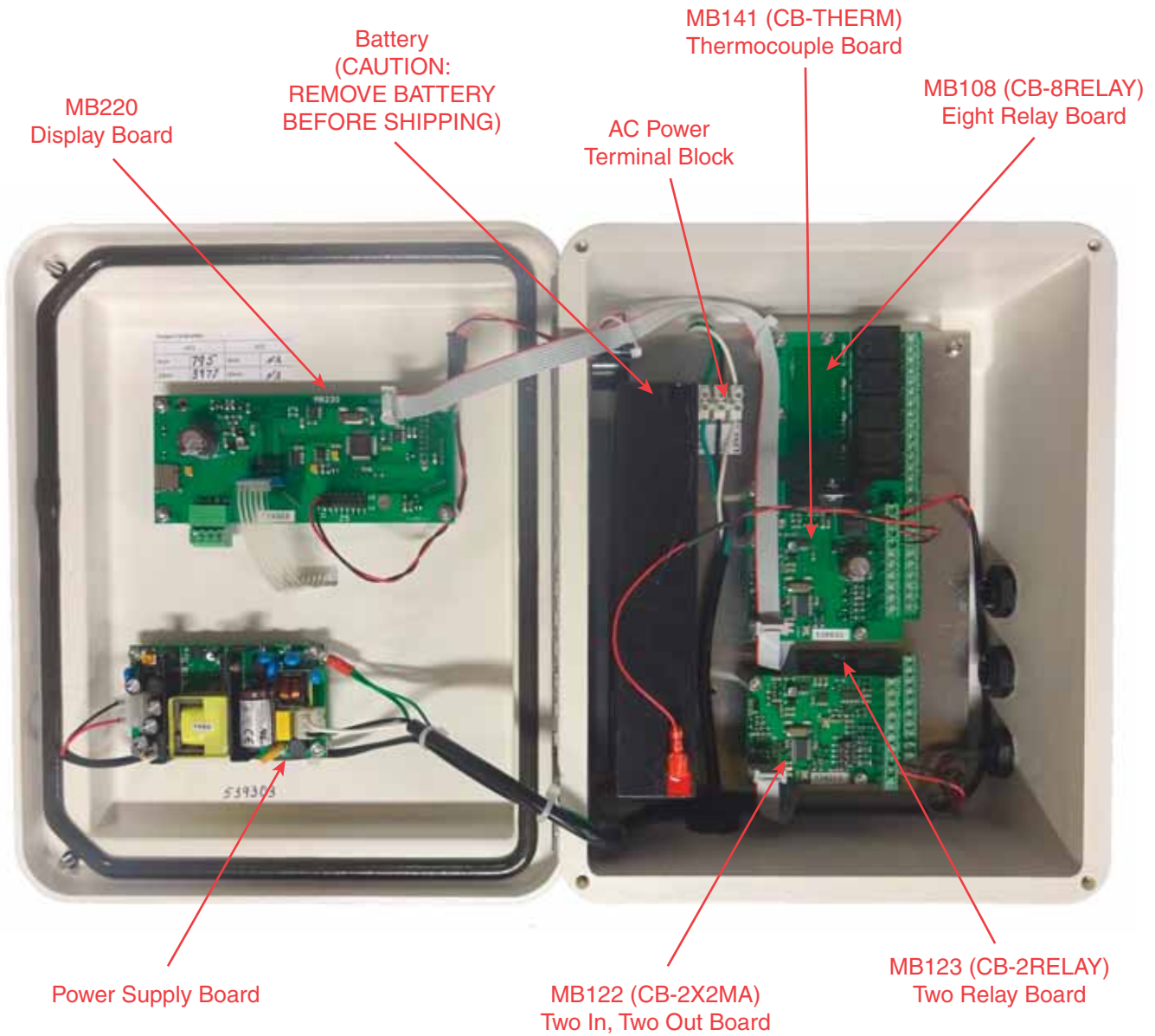

Photo of a GA-180 unit configured for two sensors with a battery backup. Some other configuration examples are summarized below.

TABLE 1: Example Controller Configurations

EXAMPLE	Maximum Sensors	Battery?	Thermocouple?	MB108 (CB-8RELAY) Eight Relay Board	MB123 (CB-2RELAY) Two Relay Board	MB122 (CB-2X2MA) Two In, Two Out Board	MB141 (CB-THERM) Thermocouple Board	MB101 (CB-BAT) Battery Board
Up To 2 Sensors, No Battery, No Thermocouple	2	No	No	1	1	1		
Up To 4 Sensors, No Battery, No Thermocouple	4	No	No	1	1	2		
Up To 4 Sensors, With Battery, No Thermocouple	4	Yes	No	1	1	2	1	
Up To 4 Sensors, No Battery, With Thermocouple	4	No	Yes	1	1	2	1	
Up To 2 Sensors, With Battery, With Thermocouple	2	Yes	Yes	1	1	1	1	1

FIGURE 5: Pinout Diagrams for MB108 and MB123

**MB108 (CB-8RELAY)
EIGHT RELAY BOARD**

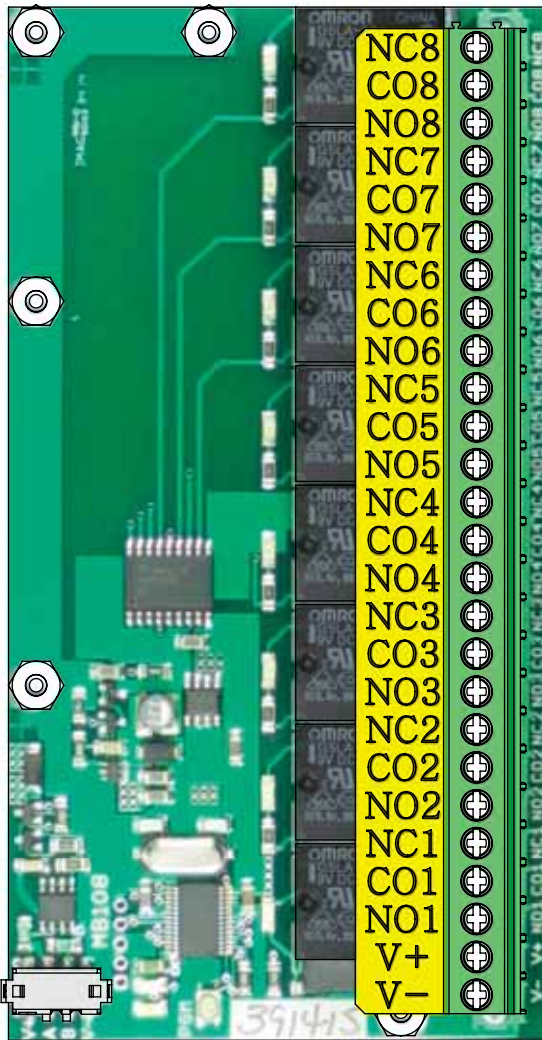

- Normally Closed 8 } RELAY 8
- Common 8 }
- Normally Open 8 }
- Normally Closed 7 } RELAY 7
- Common 7 }
- Normally Open 7 }
- Normally Closed 6 } RELAY 6
- Common 6 }
- Normally Open 6 }
- Normally Closed 5 } RELAY 5
- Common 5 }
- Normally Open 5 }
- Normally Closed 4 } RELAY 4
- Common 4 }
- Normally Open 4 }
- Normally Closed 3 } RELAY 3
- Common 3 }
- Normally Open 3 }
- Normally Closed 2 } RELAY 2
- Common 2 }
- Normally Open 2 }
- Normally Closed 1 } RELAY 1
- Common 1 }
- Normally Open 1 }
- V+
- V-

**MB123 (CB-2RELAY)
TWO RELAY BOARD**

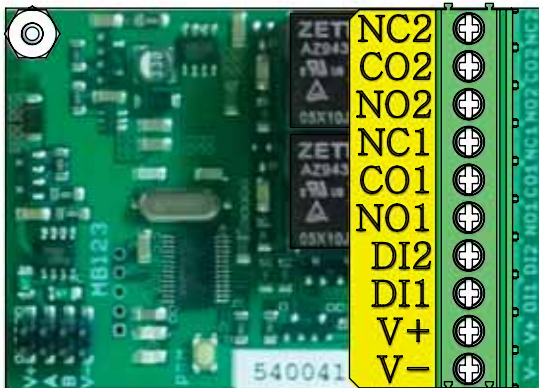

- Normally Closed 2 } RELAY 34
- Common 2 }
- Normally Open 2 }
- Normally Closed 1 } RELAY 33
- Common 1 }
- Normally Open 1 }
- *Digital Input 1 (Remote Acknowledge)

*Digital Inputs and 4-20mA outputs must also have appropriate V- (GND) connection. Relays shall be wired in either a normally open (NO) or normally closed (NC) arrangement.

FIGURE 6: Pinout Diagrams for MB122, MB141, and MB101

**MB122 (CB-2X2MA)
TWO IN, TWO OUT BOARD**

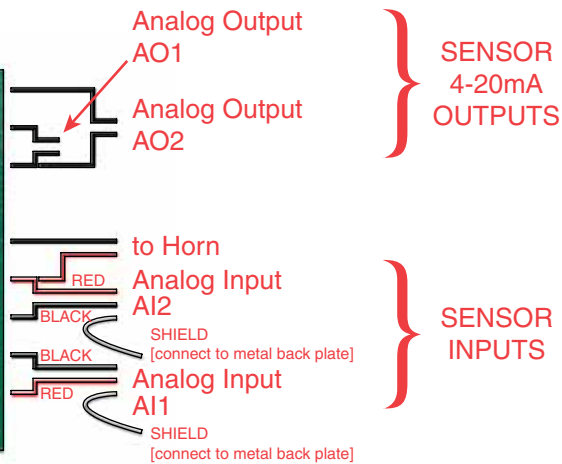
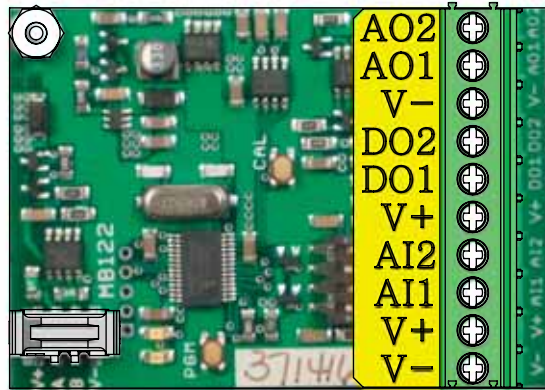

**MB141 (CB-THERM)
THERMOCOUPLE BOARD**

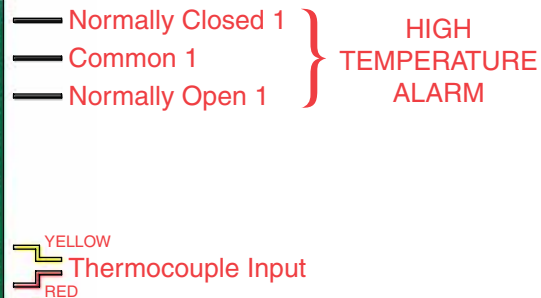
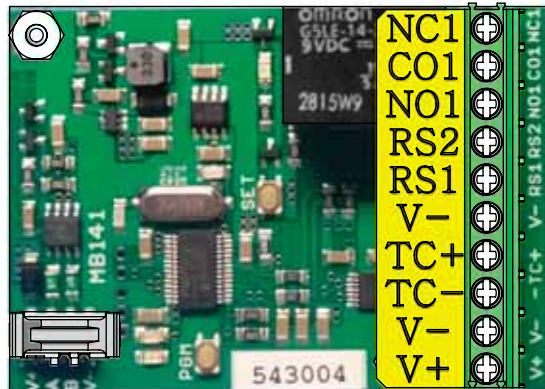

**MB101 (CB-BAT)
BATTERY BOARD**

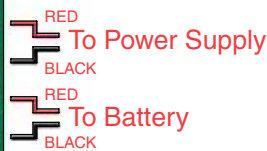
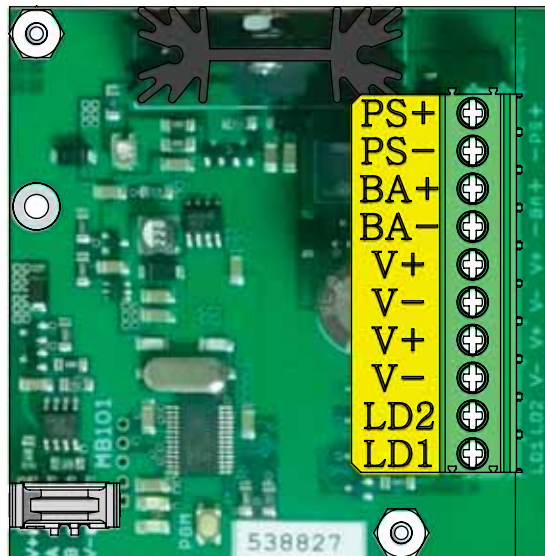

*Digital Inputs and 4-20mA outputs must also have appropriate V- (GND) connection. Relays shall be wired in either a normally open (NO) or normally closed (NC) arrangement.

II. OPERATION

A. Navigating the Controller

The GA-180 is provided with a Nema 4x, 2 line alphanumeric display controller that will display and output all important features and conditions. Navigating the controller is done by the use of four push button keys. The push button functions are described below.

⬆ key: Cycles to the previous screen.

⬇ key: Cycles to the next screen.

⊕ key: Increases/changes value, also used to enter screens.

⊖ key: Decreases/changes value.

Note: When adjusting parameter values, the number displayed is automatically saved upon leaving the screen. Thus no “enter” button is needed.

Password: All editable features of the GA-180 are password protected to prevent the unwanted tampering of the gas detector settings. To access these screens the correct password must be entered to proceed. The password for the GA-180 is “180”.

B. Operating Screens and Settings

This section gives a description of the operating screens and settings for each channel. To determine how to access each of these screens, use Figure 9.

1. **Sensor Startup:** This screen will appear at power on and allows the gas sensors five minutes to stabilize without the program running to prevent unwanted tripping of alarms and relays. Once, the five minutes has expired the program will begin. The ⊕ key can also be pressed to bypass the countdown and begin the program.
2. **Home Screens:** These screens display the gas type and current residual level of each active channel. If one or both channels are activated on a particular screen, then that screen will appear. The plug and battery symbol represent A/C power and battery power respectively. A solid symbol represents stable power. A blinking symbol represents loss of, or low power. If the battery symbol does not appear than the battery backup is not enabled.



3. **Temperature:** This screen provides a live reading of the room temperature. This screen will only appear if the thermocouple channel has been enabled.
4. **Test Operation:** This screen allows the user to test the alarm horn and all enabled relays on the GA-180. Pressing the ⊕ key will activate the horn. Pressing the ⊖ key will trip the relays.
5. **Channel Alarm Status:** These screens will notify the user of what alarm state a particular sensor channel is in, if any. Typical statuses would be “Normal”, “Danger”, “Alarm”, or “Error”. Refer to Sections II.E and III for alarm warning explanations and corrective actions.

6. **Communication Status:** Whenever a channel is activated, or a different circuit board is enabled (relays, thermocouples, battery backups) the main display CPU will request information from the relevant circuit boards to display and operate properly. The GA-180 is able to detect if any boards on this system are not communicating properly and address the user for immediate correction. Communication statuses will be “Normal” or “Error”. Refer to Sections II.F for more details.
7. **Temperature Alarm:** This screen will indicate if the air temperature in the room has exceeded the high temperature alarm setting or fallen below the low temperature alarm setting. Status will indicate one of the following: Normal, Alarm High, Alarm Low or Fail. Refer to Section II.D for more details.
8. **Password:** This screen allows access to the adjustable/configuration settings of the GA-180. Using the ⊕ and ⊖ keys, the password may be entered. The password for this unit is “180”.

C. Configuring a Sensor Channel

After the correct password has been entered, press ⊕ to proceed to the configuration mode. Using the ⊕ and ⊖ keys, select the “sensor” option so that it is blinking and press the ⊕ key to proceed to the channel configuration settings.

This section gives a description of the configuration screens and settings for each channel. To determine how to access each of these settings, use Figure 10.

1. **Configure Channel:** This screen will allow the user to enable/adjust settings to the relevant channel. The GA-180 can accept up to 16 separate channel inputs. Use the ⊕ and ⊖ keys to select the relevant channel. Once the relevant channel is blinking, press ⊕ to enter the sensor channel settings. All screens will be identical regardless of the channel selected. Settings will be adjusted and saved to each independent channel.
2. **Channel Low and High Set:** In the rising alarm configuration; in which the low set is less than the high set, the channel low set is the point *above which* the “Danger” alarm will activate. The high set is the point *above which* the “Alarm” alarm will activate.
In the falling alarm configuration; in which the low set is greater than the high set, the channel low set is the point *below which* the “Danger” alarm will activate. The high set is the point *below which* the “Alarm” alarm will activate.
Settings are adjusted using the ⊕ and ⊖ keys. Once the alarm levels are set press ⊕ to proceed to the next screen.
3. **Channel Alarm Type:** The high alarm for each channel can be set to latching or non-latching. 0 represents non-latching and 1 represents latching. These values can be adjusted using the ⊕ and ⊖ keys. When latching is selected and a high alarm occurs, the alarm will stay in an alarm state until the user has acknowledged it, even if the condition has since been alleviated.
The high alarm for each channel can also be set to failsafe or non-failsafe. 0 represents non-failsafe and 1 represents failsafe. When failsafe is selected, the high alarm relay becomes energized, in effect making the N.O. contact closed. Therefore should power be lost the relay will trip/activate.
4. **Channel Alarm Delay:** This screen allows the user to adjust the amount of time the sensor is in alarm state before the relays and other alarm features activate. This setting is adjustable from 0-60 seconds, with 5 seconds as the recommended default.

5. **Zero Calibration:** After installation, or throughout the sensor’s lifetime, the sensor signal may periodically drift from 0.0 ppm even though no gas is present. To reset this press the ⊕ key to increase the value and press the ⊖ key to decrease the value on this screen. The keys must be pressed one at a time to move the value, pressing and holding will have no effect. Wait at least 10 seconds after a new zero has been entered to confirm signal stability. A bump test should be performed after calibration.
Warning: The zero calibration should only be adjusted if the sensor is offset by 5% or less from zero. Confirm that no gas is present prior to recalibration and always ensure adequate safety procedures are enacted to confirm there is no gas present. If the value is offset by more than 5% do not recalibrate and consult Hydro Instruments for more information.
6. **Channel Gas Type and Units:** This screen allows the user to enable the sensor channel by changing the gas type from “OFF” to one of the following options “NH₃”, “O₂”, “O₃”, “SO₂”, “Cl₂”, “ClO₂”, “CO”, “H₂”, and H₂S”. The gas type must match that which the sensor is designed to detect.
7. **Channel Full Scale:** This screen allows the user to adjust the full scale of the monitor channel, so that it will match the full scale of the sensor output connected to the channel. Should the two outputs be misaligned, improper operation will result. Standard full scales for sensors supplied by Hydro Instruments can be seen in Table 1. If unsure about the full scale output of a sensor, please contact Hydro Instruments.

TABLE 2: Standard Ranges For Hydro Instruments Gas Sensors

Gas Type	Sensor Range
Chlorine (Cl ₂)	0-10 ppm
Sulfur Dioxide (SO ₂)	0-30 ppm
Ammonia (NH ₃)	0-100 ppm
Other	Consult Factory

8. **Channel Span Calibration:** The gas detector system is factory calibrated and does not require calibration upon installation setup. Span calibration is rarely required, however, it may be required or desired to perform span calibrations periodically over the life of the sensor. If calibration is to be carried out, then the appropriate span gas calibration kit must be purchased (Figures 7 and 8).
 - 8a. The calibration cap must be installed on the sensor and connected as indicated in Figures 7 and 8. Span gas must be allowed to flow at 500 cc/min for at least 1 or 2 minutes until the displayed reading stabilizes. The reading on this screen should be adjusted to match the ppm value of the span gas being used. Use the ⊕ key to increase the reading of the ⊖ key to decrease the reading. Press and release the keys one at a time. Do not press and hold the keys. After adjusting, wait 10 seconds to confirm that the reading is stable before proceeding to the next step.

FIGURE 7: Calibration Cap



FIGURE 8: Sensor and Calibration Kit



Ordering Information

Product Number	Description
GA-CK-CL2-10	Calibration Kit – 10 PPM Chlorine Gas with Regulator
GA-CRS-CL2-10	Replacement Sensor – 0-10 PPM Chlorine

Note: The sensor is shipped with the calibration cap already installed. After calibration the calibration cap should be removed for normal use. Do not dispose of the calibration cap as it will have to be reinstalled and used for any further sensor calibrations.

9. **Channel 4 mA Output Calibration:** Each sensor channel has its own isolated 4-20 mA output used for remote monitoring/indication of gas residual. Although each channel is calibrated using NIST certified equipment, it may be necessary to adjust the output of from the controller to match the input of the remote system. This screen allows the user to adjust the A/D count that outputs the 4 mA signal. Pressing the **+** key will increase the current output and pressing the **-** key will decrease the output.
10. **Channel 20 mA output Calibration:** Similar to screen #9 (4 mA Output Calibration), this screen allows the user to make minor adjustments to the A/D value that controls the 20 mA output. Pressing the **+** key will increase the current output and pressing the **-** key will decrease the output.
11. **Channel Filter Time:** This filter time is used to eliminate unwanted signal disturbances from the sensor. The filter time can be set anywhere from 0-60 seconds using the **+** and **-** keys. The recommended factory default value is 5 seconds.
12. **Calibration Diagnostic Screen:** This screen allows the user to view the most recent calibration points and their corresponding A/D values for diagnostic purposes.
13. **Live diagnostic Screen:** This screen allows the user to see the current sensor value, A/D value and current output for a particular sensor.

FIGURE 9: GA-180 Operating Screens

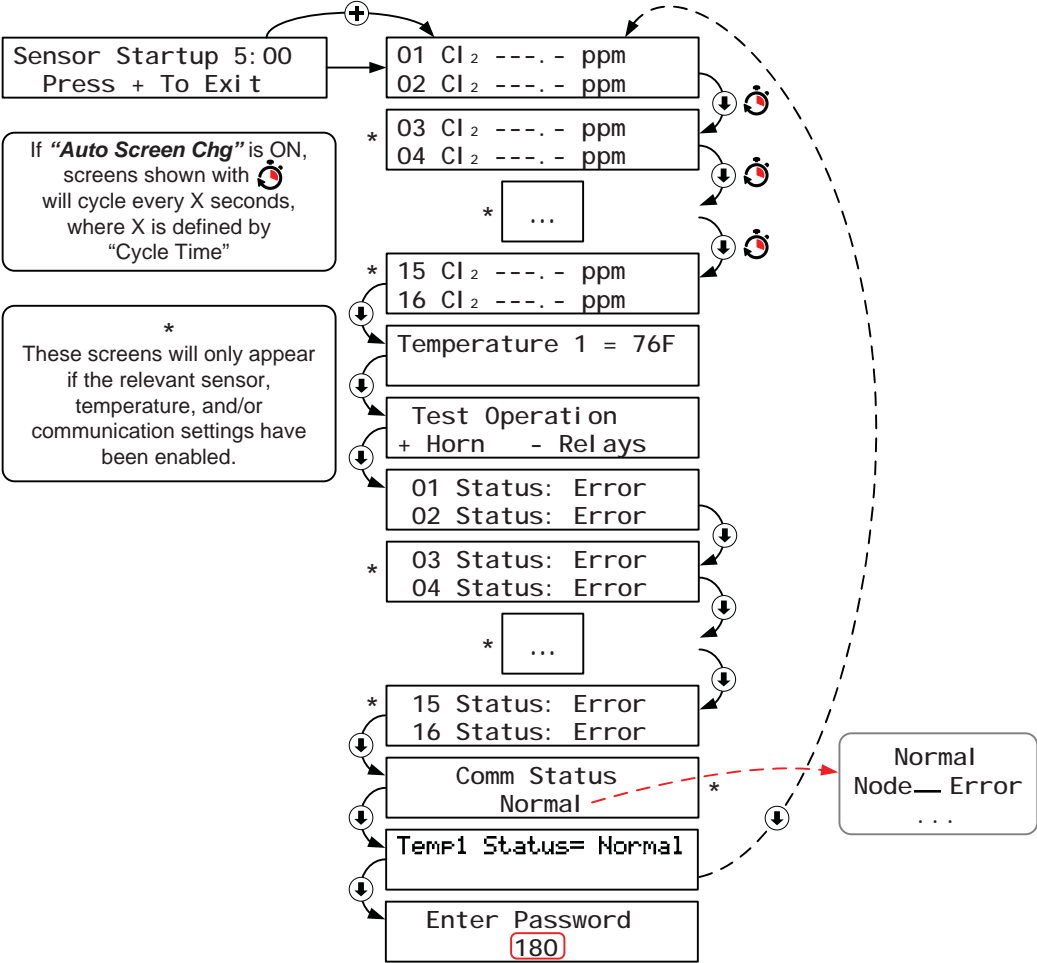

FIGURE 10: GA-180 Configuration Screens

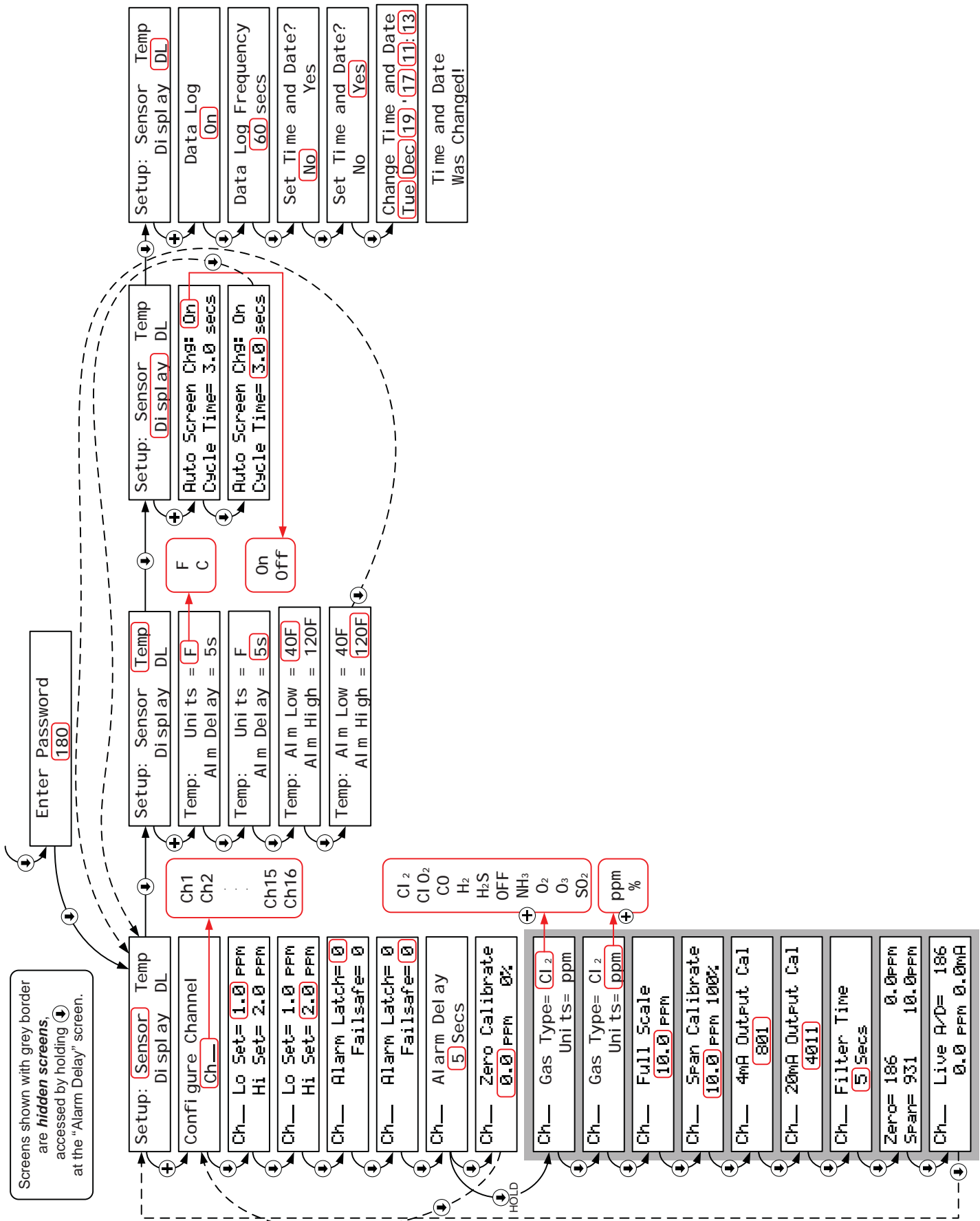
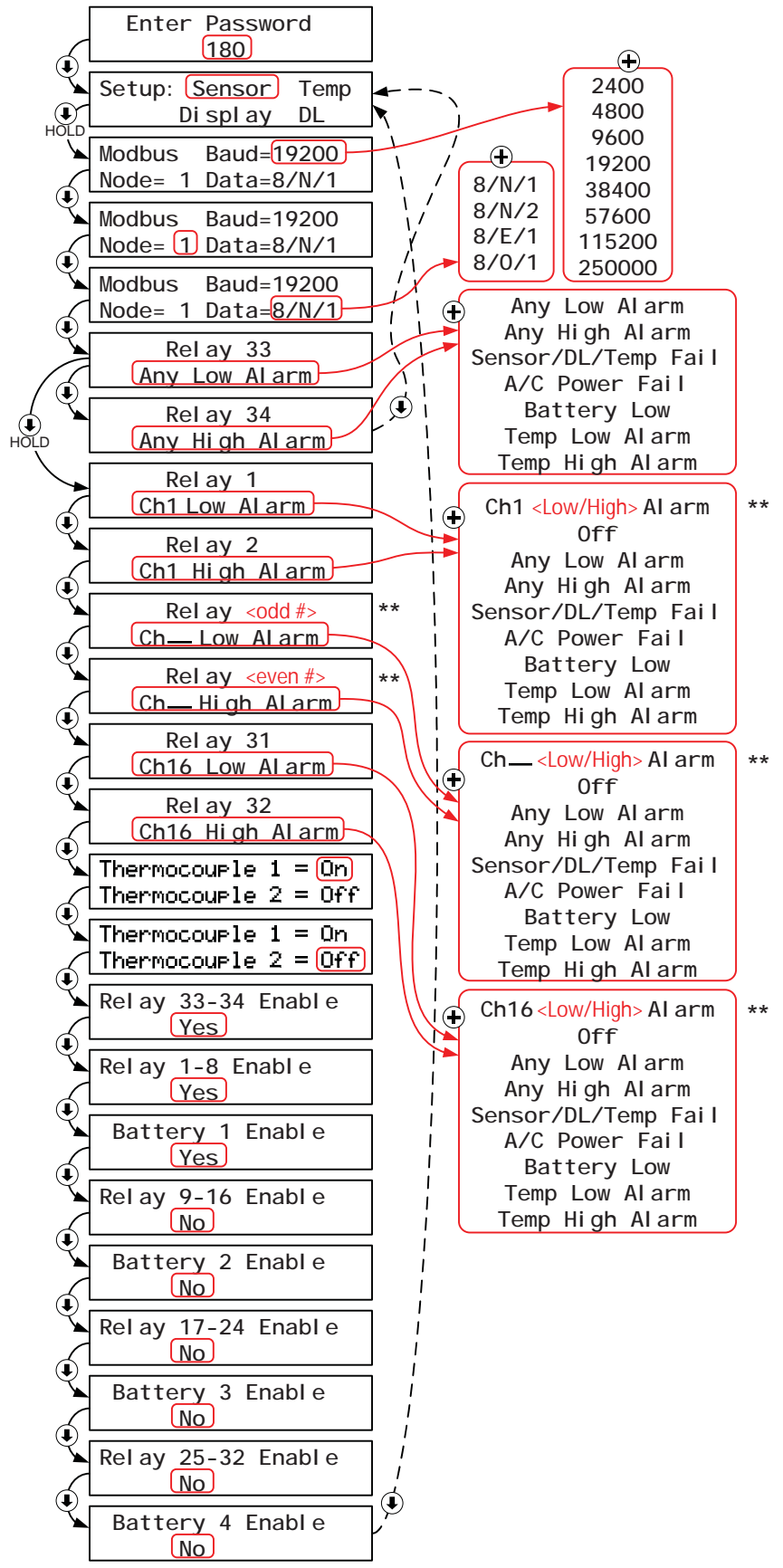

FIGURE 11: GA-180 Modbus Configuration and Node Enable Screens

**
Low and High Alarms for specific channels can be accessed according to the table below. In general, odd numbered relays can access Low Alarms, and even numbered relays can access High Alarms.

Channel	Relay	Alarm	Relay	Alarm
1	1	Ch1 Low Alarm	2	Ch1 High Alarm
2	3	Ch2 Low Alarm	4	Ch2 High Alarm
3	5	Ch3 Low Alarm	6	Ch3 High Alarm
4	7	Ch4 Low Alarm	8	Ch4 High Alarm
5	9	Ch5 Low Alarm	10	Ch5 High Alarm
6	11	Ch6 Low Alarm	12	Ch6 High Alarm
7	13	Ch7 Low Alarm	14	Ch7 High Alarm
8	15	Ch8 Low Alarm	16	Ch8 High Alarm
9	17	Ch9 Low Alarm	18	Ch9 High Alarm
10	19	Ch10 Low Alarm	20	Ch10 High Alarm
11	21	Ch11 Low Alarm	22	Ch11 High Alarm
12	23	Ch12 Low Alarm	24	Ch12 High Alarm
13	25	Ch13 Low Alarm	26	Ch13 High Alarm
14	27	Ch14 Low Alarm	28	Ch14 High Alarm
15	29	Ch15 Low Alarm	30	Ch15 High Alarm
16	31	Ch16 Low Alarm	32	Ch16 High Alarm



D. Installing and Configuring Temperature

1. Determine adequate mounting location for thermocouple and support bracket. Mount the support bracket to a wall or fixture using appropriate hardware (hardware not supplied with GA-180).
2. If necessary, connect the thermocouple to the thermocouple circuit board using the TI + and TI- terminals. Connect the Red wire to TI- and the Yellow wire to TI+. Only type K thermocouples can be used on the GA-180.
3. If necessary, connect the thermocouple board (MB141) to the display through the Modbus connector.
4. If necessary, enable the thermocouple communication. Follow the screen tree (Figure 11) to navigate to the screen “thermocouple enable”. Change to yes by pressing the ⊕ key and cycle the power. Unless you turn the power off and back on, the change will not take effect.
5. Check communication by confirming that the appropriate live temperature screen and temperature alarm screen have appeared in the correct area (Figure 9).
6. Using the screen tree (Figure 10), navigate to the “Temperature Units” screen. Units can be adjusted between “F” for Fahrenheit and “C” for Celsius. Select the appropriate unit using the ⊕ and ⊖ keys.
7. Press ⊕ and select the high and low temperature alarm points. Values can be selected anywhere from 0-255 F/C. Hydro Instruments recommends the high temperature alarm setting be at least 20°F lower than the fusible plug melting point of gas cylinders and/or ton containers. Contact your chemical supplier to confirm the temperature for the fusible plug melting point. Other equipment or local restrictions may apply. Each value is adjusted using the ⊕ and ⊖ keys.
8. Press ⊕ and select the alarm delay time. This setting sets the amount of time the temperature must remain above the high temp. alarm setting or below the low temp. alarm setting before the alarm will activate. Values can be set in the range of 0-60 seconds. Values are adjusted using the ⊕ and ⊖ keys. Press ⊕ to exit the thermocouple configuration.

E. Alarms and Outputs

1. **Alarm Status Definitions:**
 - a. Normal – The sensor is operating normally and is below the “Danger” set point.
 - b. Danger – The sensor reading has reached or exceeded the “Lo Set” level, but is lower than the “Hi Set” level. Refer to Section II.C and Figure 10 Screen 2 for additional details.
 - c. Alarm – The sensor reading has reached or exceeded the “Hi Set” level. Refer to Section II.C and Figure 10 Screen 2 for additional details.
 - d. Error – The sensor signal has been lost.

Alarms: The GA-180 comes with two common relays and eight sensor relays to every four sensors ordered. The two common relays (relay 33 and relay 34) can be configured to any of the alarm conditions outlined in Table 2. The sensor relays can be configured to any of the alarm conditions outlined in Table 2. All relays are dry contacts with a maximum power rating of 10 A.

To change any alarm relay to an alarm condition outlined in Tables 2 & 3. Follow the configuration screen layout screen tree. Once at the appropriate relay, change the alarm condition by pressing the ⊕ key. Cycle the power to save the new condition.

TABLE 3: Relay Options for Common Relays (33 & 34)

Relay	Options
Relay 33 & 34	Any Sensor High
	Any Sensor Low
	Any Sensor Signal Loss
	Loss of AC Power (must have battery backup)
	Loss of / Low Battery Power (must have battery backup)

TABLE 4: Relay Options for Sensor Relays (1-32)

Relay	Options
Odd Numbered	Ch_ low alarm
	Any sensor low
	Any sensor high
	Any sensor signal loss
	Loss of A/C Power (must have battery backup)
	Loss of / Low Battery Power (must have battery backup)
Even Numbered	Ch_ High alarm
	Any sensor low
	Any sensor high
	Any sensor signal loss
	Loss of AC Power (must have battery backup)
	Loss of / Low Battery Power (must have battery backup)

2. **Acknowledgement of Alarms:** If an alarm condition occurs, the alarm (red) LED will illuminate and the relay will be activated. To acknowledge an alarm (and deactivate the relay) for all sensors in the “Alarm” condition press the ⊖ key. Pressing the ⊖ key once will inactivate the horn, pressing the ⊖ key twice will inactivate the relay. Alarms can also be acknowledged remotely through the use of a SCADA system / PLC. To do this, connect a contact input to the DI1 input terminal on the 2 relay board (MB123) and to a relevant ground. Connecting the input once will inactivate the horn, connecting the input twice will inactivate the relay.

Note: Even after acknowledging the alarm, both LEDs will remain illuminated until the alarm condition has been removed.

3. **Alarm Explanation: Rising and Falling Alarms**

- a. **Rising:** If the Danger (low level alarm) is set to a lower value than the Alarm (high level alarm), then the GA-180 will automatically configure the channel as a rising alarm. Therefore, if the sensor reading is higher than the Danger or Alarm setting the GA-180 will activate the appropriate alarm(s). To configure a sensor rising/falling alarm, follow the steps outlined in Section II-C.
- b. **Falling:** If the Danger (low level alarm) is set to a higher value than the Alarm (high level alarm), then the GA-180 will automatically configure the channel as a falling alarm. Therefore if the sensor reading is lower than the Danger or Alarm setting the GA-180 will activate the appropriate alarm(s). To configure a sensor rising/falling alarm, follow the steps outlined in Section II-C.
- c. **Failsafe Alarms:** If a sensor channel is set to failsafe, then the corresponding Alarm (high level alarm) relay will become normally energized. This will cause a reversal of the NC/NO connections. Therefore, the normally closed connection will be open unless an alarm condition is present or power is lost. To configure a sensor failsafe alarm, follow the steps outlined in Section II-C.

4. **4-20 mA Outputs:** The GA-180 also includes isolated 4-20 mA outputs for each channel ordered. This output signal will represent the current gas residual value. See Figure 6 for 4-20mA output wiring locations.

FIGURE 12

An external alarm light with combination audible horn is an electronic device designed to alert operators and other personnel both visually and audibly to a specific danger.

Most commonly an external alarm light and horn is used with a gas leak detector to warn of gas leaks before entering a structure or room.

Features

- Single compact unit
- Wall mounting
- Rotating strobe light with red lens
- 90 dB Audible horn
- Weather resistant



Available Models

- GA-AL-110 (110VAC)
- GA-AL-220 (220VAC)

The external alarm light & horn is an optional accessory for use with all Hydro Instruments gas leak detection equipment. The alarm light connects to a relay inside the gas detector monitor. This can be a sensor specific relay or a common relay.

Alarm Light Wiring—Normally Open Relay Circuit

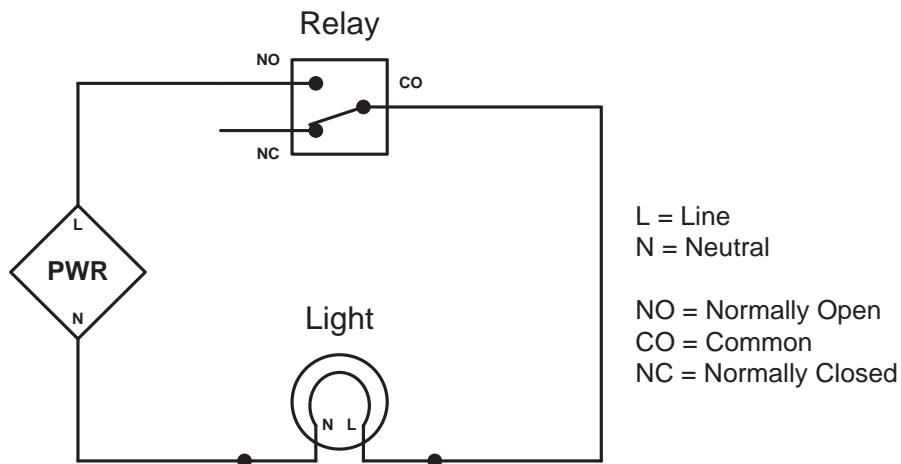

F. Modbus Communication:

Modbus RS-485 communication. The GA-180 is equipped for remote display and communication using the modbus RS-485 standard. To do this, you must define the node, baud rate and parity of the system. For more information on how to setup modbus refer to the Modbus Installation and Instruction manual. The Modbus Installation manual can be downloaded from the Hydro Instruments website (www.hydroinstruments.com). Printed copies are available upon request.

G. Bump Testing

To verify responsiveness, the gas sensors can be bump tested (exposed to a small amount of the target gas) in order to test the reaction of the sensor. A plastic squeeze bottle is provided with each gas detector for this purpose (Figure 13). It is suggested that bump testing be done at quarterly intervals, however required frequency is determined by environment, conditions, number of and severity of leaks. Proper bump testing will not substantially degrade the sensor or shorten sensor life. Figure 13 diagrams a bump testing procedure for chlorine gas. Contact Hydro Instruments for other bump testing procedures should the sensor be for something other than chlorine gas.

FIGURE 13: Bump Testing (Chlorine Gas Example)

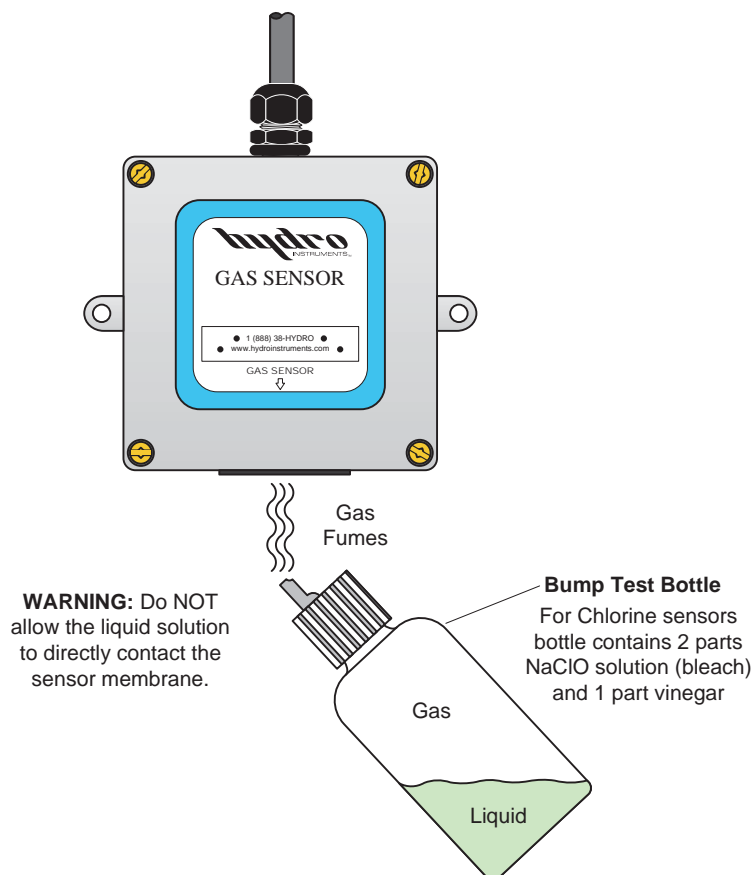

H. Data Logger

1. **Description:** If installed and enabled, the data logger records each gas sensors reading and temperature sensor reading. The frequency of recording is adjustable. The data is recorded on a MicroSDHC memory card located inside the gas alarm enclosure on the MB220 board. The MicroSDHC memory card is installed in the slot (See Figure 5). Data can be read using a text-reader program or imported into a spreadsheet program. To use the data logger the controller must be provided with the MJ500 Real Time Clock board (which mounts directly on the MB220 board as shown on Figure 5).
2. **Operation:** To enable the data logger, enter the configuration menu and select the option “DL”. The first menu option that appears will be the On/Off menu to enable/disable the data logger. The menus that follow allow for adjustment of data recording frequency and for changes to the clock (date and time). See Figure 10.
 - a. **Frequency:** The frequency is the time interval between data recordings. The frequency is adjustable in seconds, with a minimum setting of 5 seconds.
 - b. **Data Logger Clock:** The clock is factory-set before shipment. However, because the clock is set on Eastern Standard time it may be necessary to change the date and time upon start-up.
3. **Stored Data Files:** The data will be written to text files on the MicroSDHC memory card. The formatting and handling of these files is as described below:
 - a. **File Format:** The following is an example data file to illustrate the format used. As you can see, there is a three line header for each file. The fourth and fifth lines are headers for the data. You will see that each header and data entry is delimited by a comma.
 - b. **File Name:** Each data file will be named according to the date on which it was created. For example if created on May 24, 2017, the file name would be May24_17.txt
 - i. If the MicroSDHC memory card already has a file started earlier on the same day, then data will be written onto the existing file.
 - ii. The text files are limited to 5 MB. Once this limit has been reached, a new file will automatically be created to allow data to continue to be written.
 - c. **Importing data into a spreadsheet:** The data files can be imported into a spreadsheet program. The data format is ‘comma separated values’.

III. TROUBLESHOOTING

A. Installation Check – Review each of the following points first.

1. **Sensor Installation:** Check the following points regarding the sensor installation.
 - a. Sensor enclosure cover must be securely fastened to protect against corrosion of the transmitter board etc.
 - b. Sensor must be mounted at a height that is according to Figures 1a and 1b.
 - c. Sensor must be mounted so that (rain) water cannot come into contact with the sensor element. Water coming into contact with the sensor element will damage the sensor and cause the need for sensor replacement. Generally, water damage will cause the sensor to have an above zero reading that will not return to zero.
 - d. Ensure that the sensor calibration cap has been removed completely. See Figure 2.
2. **Monitor Installation:** Check the following points regarding monitor installation.
 - a. Monitor should be installed at eye level in a location that is suitable for personnel to check the sensor status before entering the chemical storage room.
 - b. Monitor should be mounted in a location that is protected from rain and it is recommended that it should not be mounted under direct sunlight.
 - c. Monitor enclosure bolts must be securely fastened and wiring seal tights must be plugged if not used in order to protect against corrosion of the circuit boards etc.
 - d. Ensure that the alarm relay output and/or 4-20mA outputs are wired according to Section II.E and Figures 5 and 6.

B. Symptoms, Likely Causes, and Suggested Responses

Symptoms	Likely Causes	Suggested Responses*
Slightly off zero in air	Inaccurate zero calibration	Perform zero calibration
Zero & no response with Alarm Status: Normal	1. Calibration cap not removed 2. Wrong span calibration	1. Remove calibration cap 2. Correct span calibration
False alarm and no display response with Alarm Status: Error	1. Sensor disconnected 2. Sensor damaged	1. Check sensor wiring 2. Replace the sensor
High reading or reading that won't return to zero	Sensor damaged	Replace the sensor
Blank display	1. Lost A/C power 2. Damaged circuit board 3. Damaged power supply board	1. Check A/C Power 2. Replace circuit board 3. Replace power supply board

* See Section III.C for a more detailed explanation of the suggested responses.

C. Explanation of Responses

1. **Zero Calibration:** If the display is not reading 0.0 PPM in air, then adjust the zero calibration. Refer to Section II.C.5 and Figure 10.
2. **Calibration Cap:** The calibration cap is installed for protection of the sensor during shipping and storage, but must be removed upon installation. If the sensor cap is not removed, then there will be no response or a very slow response. Refer to Section I.B.3 and Figure 2.
3. **Span Calibration:** If the span calibration is performed incorrectly (usually accidentally done in air with zero target gas) then this will cause the readings to be inaccurate. Unless you intend to perform the span calibration and have a span gas calibration kit, do not touch the ⊕ and ⊖ keys if you enter the span calibration screen. See Section II.C.8 and Figures 7 and 8.
4. **Sensor Wiring:** If the display is reading a negative value and giving an “Alarm Status: Error” message, then the sensor may not be connected to the monitor. Check the wiring from the circuit board in the monitor to inside the sensor enclosure. See Figures 5 and 6.
5. **Sensor Replacement:** Repeated or excessive exposure to the target gas and/or cross sensitive gases will eventually cause failure of the sensor. If water is allowed to contact the sensor element this will also eventually cause failure of the sensor. Under normal circumstances a sensor life is typically 2 years or more. However, lightning, other power surges, chemical leaks, and contact with water can all cause sensor failure. Replacement sensors are easily installed with the quick disconnect fitting.
6. **Damaged Circuit Board:** The circuit boards can be damaged if high voltage is connected to the wrong terminals, by lightning, other power surges, or by corrosion. If you believe that the circuit board is damaged, then contact the factory and your local sales representative. Refer to Figures 3, 4, 5, and 6.
7. **Power Supply:** If the display board has no power, then always check to see if the power supply board is damaged and replace if necessary.