

Operating instructions

Diaphragm Motor-Driven Metering Pump

Sigma / 2 Basic Type S2Ba

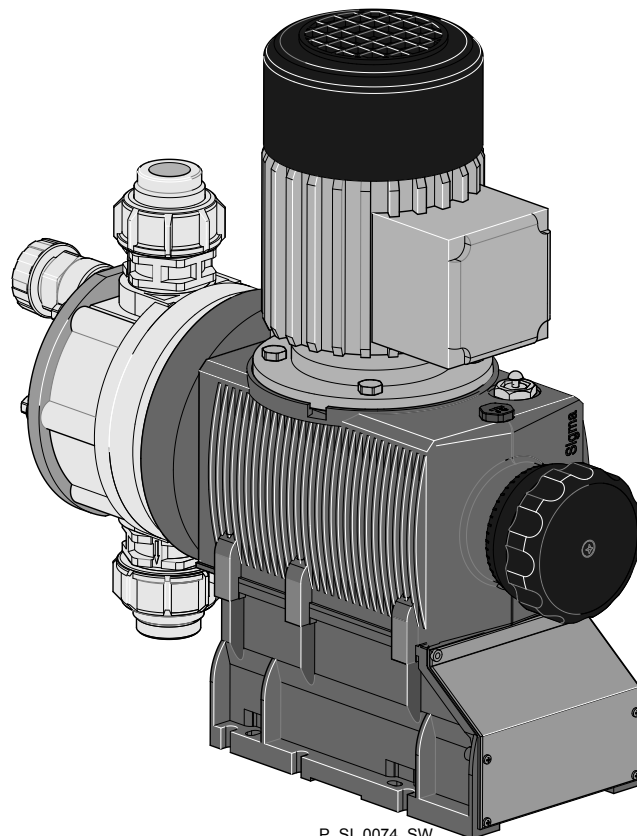

P_SI_0074_SW

**Please carefully read these operating instructions before use! · Do not discard!
The operator shall be liable for any damage caused by installation or operating errors!
Technical changes reserved.**

Supplementary information



Fig. 1: Please read!

Read the following supplementary information in its entirety! Should you already know this information, you will benefit more from referring to the operating instructions.

The following are highlighted separately in the document:

- Enumerated lists

- ➔ Operating guidelines

- ⇒ Outcome of the operating guidelines

- see (reference)

Information



This provides important information relating to the correct operation of the unit or is intended to make your work easier.

Safety notes

Safety notes are identified by pictograms - see Safety Chapter.

Validity

These operating instructions conform to current EU regulations applicable at the time of publication.

State the identity code and serial number

Please state identity code and serial number, which you can find on the nameplate when you contact us or order spare parts. This enables the device type and material versions to be clearly identified.

Table of contents

1	Identity code	4
2	Safety chapter	6
3	Storage, transport and unpacking	11
4	Overview of equipment and control elements	12
5	Functional description	14
	5.1 Pump.....	14
	5.2 Liquid end.....	14
	5.3 Integral relief valve.....	14
	5.4 Multi-layer safety diaphragm.....	15
6	Assembly	16
7	Installation, hydraulic	18
	7.1 Basic installation notes.....	22
8	Installation, electrical	23
9	Start up	28
10	Maintenance	31
11	Repairs	34
	11.1 Cleaning valves.....	35
	11.2 Replacing the diaphragm.....	36
12	Troubleshooting	40
13	Decommissioning	43
14	Technical data	45
	14.1 Performance data.....	45
	14.2 Shipping weight.....	46
	14.3 Wetted materials.....	47
	14.4 Ambient conditions.....	47
	14.4.1 Ambient temperatures.....	47
	14.4.2 Media temperatures.....	47
	14.4.3 Air humidity.....	48
	14.5 Motor data.....	48
	14.6 Stroke actuator.....	48
	14.7 Stroke control drive.....	48
	14.8 Diaphragm rupture sensor.....	48
	14.9 Stroke sensor "Sigma".....	49
	14.10 Relay.....	50
	14.11 Gear oil.....	50
	14.12 Sound pressure level.....	50
	14.13 Supplementary information for modified versions.....	50
15	Diagrams for setting the metering capacity	52
16	Dimensional drawings	53
17	Motor data sheet standard motor	56
18	Liquid ends Sigma/ 2	57
19	Wear parts for Sigma/ 2	61
	19.1 Standard.....	61
	19.2 Physiological safety.....	61
20	EC Declaration of Conformity for Machinery	63
21	EC Declaration of Conformity for Machinery Used in Areas at Risk of Explosion	64

1 Identity code

S2Ba	Sigma 2 Basic Type	
H	Main power end, diaphragm	
	Type:	Capacity
	----	Performance data at maximum back pressure and type: see nameplate on pump housing

	Dosing head material	
	PV	PVDF
	SS	Stainless steel
	Seal material	
	T	PTFE seal
	Displacement body	
	S	Multi-layer safety diaphragm with optical rupture indicator
	A	Multi-layer safety diaphragm with diaphragm rupture signalling (contact)
	H	Diaphragm for hygienic pump head
	Dosing head design	
	0	no valve springs
	1	with 2 valve springs, Hastelloy C; 0.1 bar
	4 **	with relief valve, FPM seal, no valve spring
	5 **	with relief valve, FPM seal, with valve springs
	6 **	with relief valve, EPDM seal, no valve spring
	7 **	with relief valve, EPDM seal, with valve springs
	H	Hygienic pump head with tri-clamp connectors (max. 10 bar)
	Hydraulic connector	
	0	Standard threaded connector (in line with technical data)
	1	Union nut and PVC insert
	2	Union nut and PP insert
	3	Union nut and PVDF insert
	4	Union nut and SS insert
	7	Union nut and PVDF tube nozzle
	8	Union nut and SS tube nozzle
	9	Union nut and SS welding sleeve
	Design	
	0	With ProMinent® logo (standard)
	1	Without ProMinent® logo
	F	Physiological safety with regard to wetted materials FDA No. 21 CFR §177.1550 (PTFE) FDA No. 21 CFR §177.2510 (PVDF)
	M	Modified* * order-related design, refer to order paperwork for pump features
	Electric power supply	

S2Ba		Sigma 2 Basic Type								
									–	Connection data - refer to nameplate on motor
									1	No motor, with B14 flange, size 71 (DIN)
									2	No motor, with C 42 flange (NEMA)
									3	No motor, with B 5, size 56 (DIN)
									Degree of protection	
									0	IP 55 (standard)
									1	Exe design ATEX-T3
									2	Exd version ATEX-T4
									Stroke sensor	
									0	No stroke sensor (standard)
									2	Pacing relay (reed relay)
									3	Stroke sensor (Namur) for hazardous locations
									Stroke length adjustment	
									0	Manual (standard)
									1	With servomotor, 230 V, 50/60 Hz
									2	With servomotor, 115 V, 50/60 Hz
									3	With control motor 0...20 mA 230 V, 50/60 Hz
									4	With control motor 4...20 mA 230 V, 50/60 Hz
									5	With control motor 0...20 mA 115 V, 50/60 Hz
									6	With control motor 4...20 mA 115 V, 50/60 Hz

FPM = fluorine rubber

** Standard with hose nozzle in the bypass Threaded connection on request.

2 Safety chapter



CAUTION!

These operating instructions include notes and quotes from German guidelines relating to the system operator's scope of responsibility. This information does not discharge the operator from his responsibility as an operator and is intended only to remind him or make him aware of specific problem areas. This information does not lay claim to being complete, nor applicable to every country and every type of application, nor to being unconditionally up-to-date.

Identification of safety notes

The following signal words are used in these operating instructions to denote different severities of danger:

Signal word	Meaning
WARNING	Denotes a possibly dangerous situation. If this is disregarded, you are in a life-threatening situation and this can result in serious injuries.
CAUTION	Denotes a possibly dangerous situation. If this is disregarded, it could result in slight or minor injuries or material damage.

Warning signs denoting different types of danger

The following warning signs are used in these operating instructions to denote different types of danger:

Warning signs	Type of danger
	Warning – high-voltage.
	Warning – danger zone.

Intended use

- Only use the pump to meter liquid metering chemicals.
- In potentially explosive atmospheres in zone 1, device category II 2G, explosion group II C, only operate the pump with the appropriate nameplate (and the respective EC Declaration of Conformity) for pumps for use in areas at risk of explosion in compliance with Directive 94/9/EC in accordance with the European guidelines. The explosion group, category and degree of protection specified on the label should correspond to or be better than the conditions given in the intended field of application.
- Only pumps with the identity code option "Multi-layer safety diaphragm with visual rupture display" and "Multi-layer safety diaphragm with rupture signalling (contact)" are approved for use with flammable feed chemicals, at back pressures of over 2 bar and if the operator takes appropriate safety measures.
- Only pumps with the design "F - Physiological safety with regard to wetted materials" are approved for use with physiologically harmless applications.
- Only start up the pump after it has been correctly installed and commissioned in accordance with the technical data and specifications contained in the operating instructions.

- Observe the general limitations with regard to viscosity limits, chemical resistance and density - see also ProMInent Resistance List (in the Product Catalogue or at www.prominent.com/en/downloads)!
- All other uses or modifications are prohibited.
- Never operate pumps without the relevant nameplate (and the respective EC Declaration of Conformity) for pumps for use in atmospheres at risk from explosion in atmospheres potentially at risk from explosion.
- The pump is not intended for the metering of gaseous media or solids.
- The pump is not intended to meter explosive substances and mixtures.
- The pump is not intended for unprotected outside use.
- The pump is only intended for industrial use.
- The pump should only be operated by trained and authorised personnel.
- Observe the information contained in the operating instructions at the different phases of the device's service life.

Qualification of personnel

Action	Qualification
Storage, transport, unpacking	Instructed person
Assembly	Technical personnel, service
Planning hydraulic installation	Qualified personnel who have a thorough knowledge of oscillating diaphragm pumps.
Hydraulic installation	Technical personnel, service
Installation, electrical	Electrical technician
Operation	Instructed person
Maintenance, repair	Technical personnel, service
Decommissioning, disposal	Technical personnel, service
Troubleshooting	Technical personnel, electrical technician, instructed person, service

Explanation of the terms:

Technical personnel

A qualified employee is deemed to be a person who is able to assess the tasks assigned to him and recognise possible dangers based on his/her technical training, knowledge and experience, as well as knowledge of pertinent regulations.

Note:

A qualification of equal validity to a technical qualification can also be gained by several years employment in the relevant work area.

Electrical technician

Electrical technicians are deemed to be people, who are able to complete work on electrical systems and recognise and avoid possible dangers independently based on their technical training and experience, as well as knowledge of pertinent standards and regulations.

Electrical technicians should be specifically trained for the working environment in which they are employed and know the relevant standards and regulations.

Electrical technicians must comply with the provisions of the applicable statutory directives on accident prevention.

Instructed person

An instructed person is deemed to be a person who has been instructed and, if required, trained in the tasks assigned to him/her and possible dangers that could result from improper behaviour, as well as having been instructed in the required protective equipment and protective measures.

Service

Customer Service department refers to service technicians, who have received proven training and have been authorised by ProMinent or ProMaqua to work on the system.

Safety notes



WARNING!

- Observe the European Operator Directive 99/92/EC (ATEX 137), implemented in Germany by the Industrial Health and Safety Regulation and the German Ordinance on Hazardous Substances, for the installation and operation of equipment in areas at risk from explosion.
- Observe the European standards EN 1127-1, EN 60079-10, EN 60079-14, EN 60079-17 and EN 60079-25 and EN 50039 for inherently safe electrical circuits. (In Germany these standards are partly implemented by VDE 0165 and VDE 0118).
- Adhere to the respective national regulations outside of the EU.
- Ensure that installations in areas at risk from explosion are checked by a "recognisably trained" skilled operative. This applies specifically to intrinsically safe electrical circuits.
- The following information relates essentially to the unique characteristics in areas at risk from explosion but does not replace the standard operating instructions.
- Only clean plastic parts carefully with a damp cloth to avoid electrostatic charges and sparks.



WARNING!

Warning of dangerous or unknown feed chemical

Should a dangerous or unknown feed chemical be used: It may escape from the hydraulic components when working on the pump.

- Take appropriate protective measures before working on the pump (e.g. safety glasses, safety gloves, ...). Observe the safety data sheet for the feed chemical.
- Drain and flush the liquid end before working on the pump.



WARNING!

Danger from hazardous substances!

Possible consequence: Fatal or very serious injuries.

Please ensure when handling hazardous substances that you have read the latest safety data sheets provided by the manufacture of the hazardous substance. The actions required are described in the safety data sheet. Check the safety data sheet regularly and replace, if necessary, as the hazard potential of a substance can be re-evaluated at any time based on new findings.

The system operator is responsible for ensuring that these safety data sheets are available and that they are kept up to date, as well as for producing an associated hazard assessment for the workstations affected.



CAUTION!

Warning of feed chemical spraying around

Feed chemical can spray out of the hydraulic components if they are manipulated or opened due to pressure in the liquid end and adjacent parts of the system.

- Disconnect the pump from the mains power supply and ensure that it cannot be switched on again by unauthorised persons.
- Depressurise the system before commencing any work on hydraulic parts.



CAUTION!

Warning of feed chemical spraying around

An unsuitable feed chemical can damage the parts of the pump that come into contact with the chemical.

- Take into account the resistance of the wetted materials when selecting the feed chemical - see the ProMinent product catalogue or visit www.prominent.com/en/downloads.



CAUTION!

Danger of personnel injury and material damage

The use of untested third party parts can result in personnel injuries and material damage.

- Only fit parts to metering pumps, which have been tested and recommended by ProMinent.



CAUTION!

Danger from incorrectly operated or inadequately maintained pumps

Danger can arise from a poorly accessible pump due to incorrect operation and poor maintenance.

- Ensure that the pump is accessible at all times.
- Adhere to the maintenance intervals.

Safety equipment



WARNING!

- Attach the following safety note to pumps that contain parts made of electrically non-conductive plastic.
- Ensure that the label is always fitted and legible.

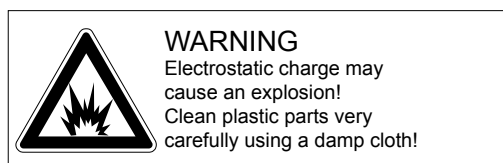

Fig. 2

Isolating protective equipment

All isolating protective equipment must be installed for operation:

- Drive front cover
- Motor fan cowling
- Terminal box cover, motor

Only remove them when the operating instructions request you to do so.

Information in the event of an emergency

In the event of an electrical accident, disconnect the mains cable from the mains or press the emergency cut-off switch fitted on the side of the system!

If feed chemical escapes, also depressurise the hydraulic system around the pump as necessary. Adhere to the safety data sheet for the feed chemical.

Safety information relating to the operating instructions

Prior to commissioning the system or system component, the system operator is obliged to obtain the latest safety data sheet from the supplier for the chemicals / resources to be used with the system. The operator should create the legal framework for safe operation of the system or system component, such as for example the preparation of operating instructions (operator duties), based on the information provided in the data sheets concerning health and safety, water and environmental protection and taking into consideration the actual operating environment on site.

Sound pressure level

Sound pressure level LpA < 70 dB according to EN ISO 20361

at maximum stroke length, maximum stroke rate, maximum back pressure (water)

3 Storage, transport and unpacking

Safety notes



WARNING!

Only return the metering pump for repair in a cleaned state and with a flushed liquid end - refer to the chapter "Decommissioning"!

Only return metering pumps with a completed Decontamination Declaration form. The Decontamination Declaration constitutes an integral part of an inspection / repair order. A unit can only be inspected or repaired when a Declaration of Decontamination Form is submitted that has been completed correctly and in full by an authorised and qualified person on behalf of the pump operator.

The "Decontamination Declaration Form" can be found at www.prominent.com/en/downloads.



WARNING!

Slings can tear

ProMinent only supplies non-reusable slings. These can tear with repeated use.

- Only use the slings once.



CAUTION!

Danger of material damage

The device can be damaged by incorrect or improper storage or transportation!

- The unit should only be stored or transported in a well packaged state - preferably in its original packaging.
- Only transport the unit when the red gear bleeding plug is pushed in.
- The packaged unit should also only be stored or transported in accordance with the stipulated storage conditions.
- The packaged unit should be protected from moisture and the ingress of chemicals.

Scope of supply

Compare the delivery note with the scope of supply:

Storage

Personnel: Technical personnel

1. Plug the caps on the valves.
2. Check if the red gear bleeding plug is pushed in.
3. Preferably place the pump standing vertically on a pallet and secure against falling over.
4. Cover the pump with a tarpaulin cover - allowing rear ventilation.

Store the pump in a dry, sealed place under the ambient conditions according to chapter "Technical Data".

4 Overview of equipment and control elements

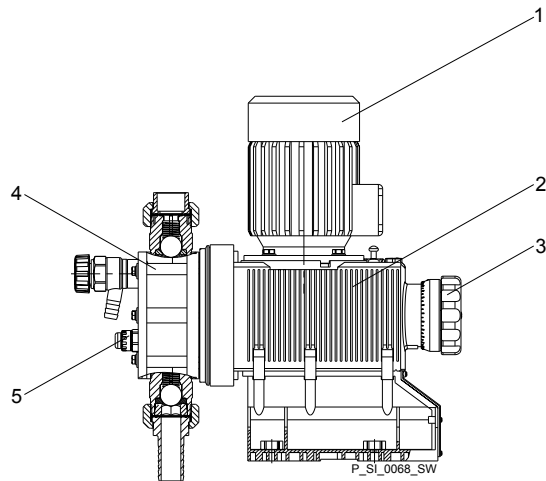

Fig. 3: Overview of equipment and control elements S2Ba

- 1 Drive motor
- 2 Drive unit
- 3 Stroke length adjustment knob
- 4 Liquid end with relief valve
- 5 Diaphragm rupture sensor

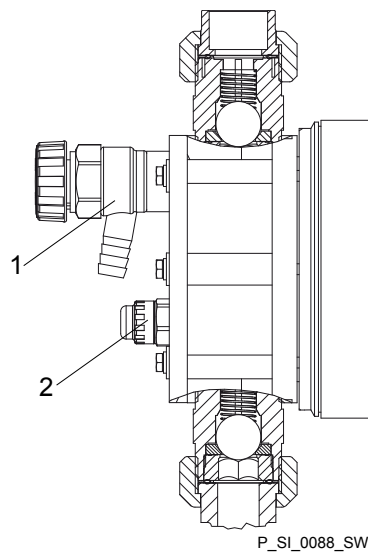

Fig. 4: Sigma control elements

- 1 Relief valve
- 2 Diaphragm rupture sensor (visual)

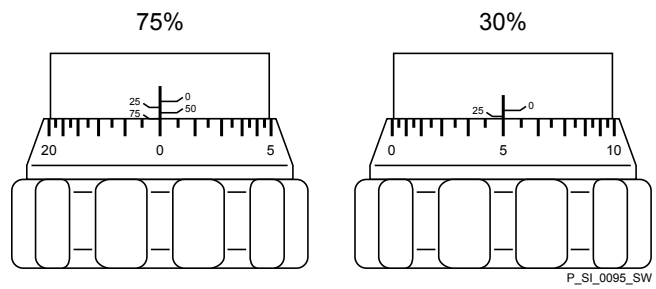

Fig. 5: Adjusting the stroke length

- 100 % = 4 rotations
- 25 % = 1 rotation
- 0.5 % = 1 scale mark on stroke adjustment dial

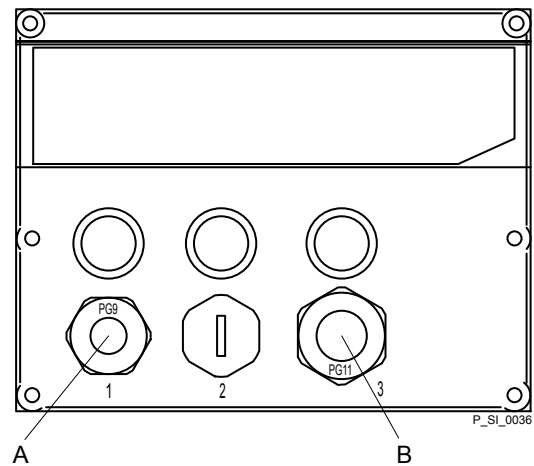

Fig. 6: Front cover for version with pacing relay

- A Pacing relay cable
- B Supply voltage cable for pacing relay PCB

5 Functional description

5.1 Pump

The metering pump is an oscillating diaphragm pump, the stroke length of which is adjustable. An electric motor drives the pump.

5.2 Liquid end

The diaphragm (2) hermetically shuts off the pump volume of the dosing head (4) towards the outside. The suction valve (1) closes as soon as the diaphragm (2) is moved in to the dosing head (4) and the feed chemical flows through the discharge valve (3) out of the dosing head. The discharge valve (3) closes as soon as the diaphragm (2) is moved in the opposite direction due to the vacuum pressure in the dosing head and fresh feed chemical flows through the suction valve (1) into the dosing head. One cycle is thus completed.

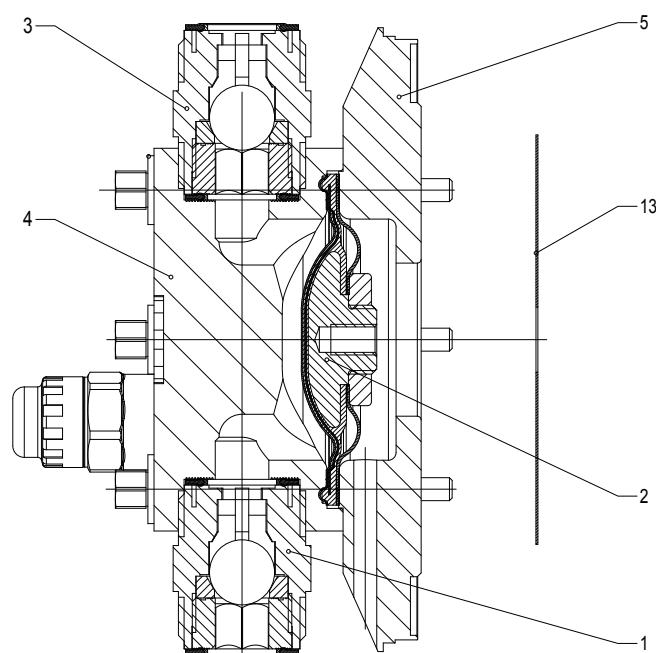

Fig. 7: Cross-section through the liquid end

- 1 Suction valve
- 2 Diaphragm
- 3 Discharge valve
- 4 Dosing head
- 5 Backplate
- 13 Safety diaphragm

5.3 Integral relief valve

The integral relief valve normally operates as a simple, directly controlled **bleeder valve**. The feed chemical then flows out through the hose connection, e.g. into a storage tank, as soon as the pressure exceeds the pre-set pressure value.

The integral relief valve can only protect the motor and the gear, and then only against impermissible positive pressure that is caused by the metering pump itself. It cannot protect the system against positive pressure.

The integral relief valve works as a **bleed valve** if the rotary dial is turned clockwise up to the "open" stop, acting as a priming aid when starting up the pump against pressure.

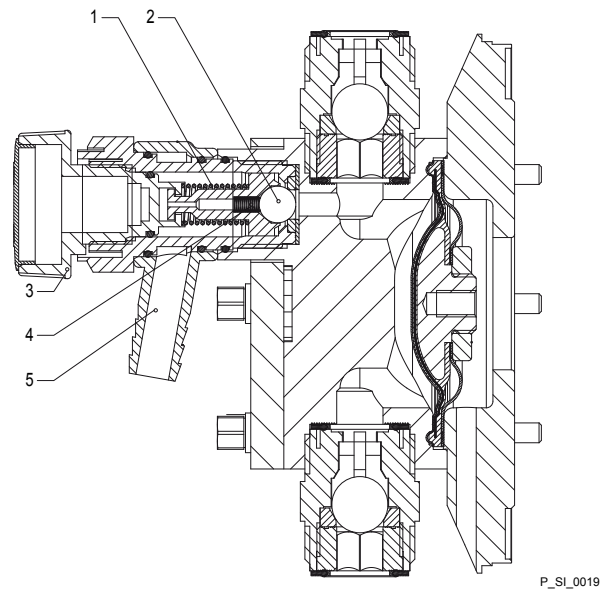

Fig. 8: Integral relief valve

- 1 Spring, large
- 2 Ball
- 3 Rotary dial
- 4 Spring, small
- 5 Hose connection

5.4 Multi-layer safety diaphragm

With **visual** diaphragm rupture sensors, in the event of a diaphragm rupture, the lowered red cylinder (6) springs forward beneath the transparent cover (7) so that it then becomes clearly visible - see Fig. 9.

With the **electrical** diaphragm rupture sensor, a switch is switched. A signalling device must be connected to signal the diaphragm rupture.

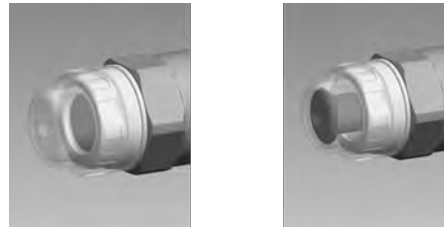

Fig. 9: Visual diaphragm rupture sensor, triggered and untriggered

6 Assembly



Compare the dimensions on the dimension sheet and pump.

Base

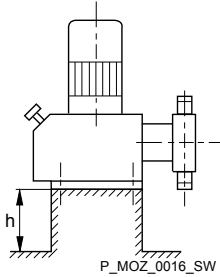

Fig. 10



WARNING!
Danger of electric shock

If water or other electrically conducting liquids penetrate into the drive housing, in any other manner than via the pump's suction connection, an electric shock may occur.

- Position the pump so that it cannot be flooded.



WARNING!
The pump can break through the base or slide off it

- Ensure that the base is horizontal, smooth and permanently load-bearing.



Capacity too low

Vibrations can disrupt the liquid end valves.

- The supporting floor must not vibrate.

Space requirement

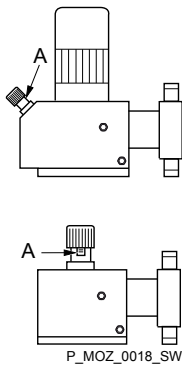

Fig. 11



CAUTION!
Danger from incorrectly operated or inadequately maintained pumps

Danger can arise from a poorly accessible pump due to incorrect operation and poor maintenance.

- Ensure that the pump is accessible at all times.
- Adhere to the maintenance intervals.

Position the pump so that control elements such as the stroke length adjustment knob or the indicating dial A are easily accessible.

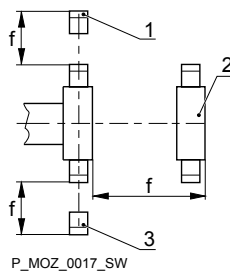

Fig. 12

- 1 Discharge valve
- 2 Dosing head
- 3 Suction valve

Ensure that there is sufficient free space (f) around the dosing head, as well as the suction and discharge valve, so that maintenance and repair work can easily be carried out on these components.

Liquid end alignment



Capacity too low

The liquid end valves cannot close correctly if they are not upright.

- *Ensure that the discharge valve is upright.*

Fastening



Capacity too low

Vibrations can disrupt the liquid end valves.

- *Secure the metering pump so that no vibrations can occur.*

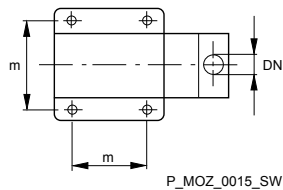

Fig. 13

Take the dimensions (m) for the fastening holes from the appropriate dimensional drawings or data sheets.

Fix the pump base to the base with suitable screws.

7 Installation, hydraulic



WARNING!

EX pumps in areas at risk from explosion

- It is essential that metering pumps to be used in areas at risk from explosion are fitted with an appropriate safety relief valve on the outlet side of the metering pump (to protect it from excessive heating up from overloading and from impact sparks resulting from overloading triggered by the breakage of drive parts).
- In the event of different temperature classes with the various components, the possible uses of the complete pump are based on the component with the lowest temperature class.
- Diaphragm pump with mechanically actuated diaphragm, e.g. MTMa., TZMa., Sigmas S1Ba..., S2BaHM..., S3Ba: no additional action is required, but in principle use the design with Ex"i" diaphragm rupture indicator.
- Ensure that installations in areas at risk from explosion are checked by a "recognisably qualified and skilled" operative.
- Please observe the relevant national regulations and guidelines during installation!



WARNING!

Danger of fire with flammable feed chemicals

- Combustible media may only be transported using stainless steel dosing heads. In exceptional cases where this is not possible, PTFE with carbon can be used, whereby our TT_ versions are manufactured from this conducting plastic. Here, the operator is urged to take special care due to the low mechanical strength.
- Only designs of metering pump with Ex"i" diaphragm rupture indicators are permitted in principle to meter flammable media.
- The following applies to all metering pumps for the metering of combustible media:
During filling and draining of the liquid end, an expert must ensure that feed chemical does not come into contact with oxygen.



WARNING!

Warning of feed chemical reactions to water

- Feed chemicals that should not come into contact with water may react to residual water in the liquid end that may originate from works testing.
- Blow the liquid end dry with compressed air through the suction connector.
 - Then flush the liquid end with a suitable medium through the suction connector.



WARNING!

The following measures are an advantage when working with highly aggressive or hazardous feed chemicals:

- Install a bleed valve with recirculation in the storage tank.
- Install an additional shut-off valve on the discharge or suction ends.



CAUTION!

Warning of feed chemical spraying around

PTFE seals, which have already been used / compressed, can no longer reliably seal a hydraulic connection.

- New, unused PTFE seals must always be used.



CAUTION!

Suction problems possible

The valves may no longer close properly with feed chemicals with a particle size of greater than 0.3 mm.

- Install a suitable filter in the suction line.



CAUTION!

Warning against the discharge line bursting

With a closed discharge line (e.g. due to a clogged discharge line or by closing a valve), the pressure that the metering pump generates can reach several times the permissible pressure of the system or the metering pump. This could lead to lines bursting, resulting in dangerous consequences with aggressive or toxic feed chemicals.

- Install a relief valve that limits the pressure of the pump to the maximum permissible operating pressure of the system.



CAUTION!

Uncontrolled flow of feed chemical

Feed chemicals can leak through a stopped metering pump if there is back pressure.

- Use an injection valve or a vacuum breaker.



CAUTION!

Uncontrolled flow of feed chemical

Feed chemical can leak through the metering pump in an uncontrolled manner in the event of excessive priming pressure on the suction side of the metering pump.

- Do not exceed the maximum permissible priming pressure for the metering pump.
- Arrange the installation properly.



CAUTION!

Warning against leaks

Leaks can occur on the pump connection depending on the insert used.

- The pump is supplied with PTFE moulded composite seals with a flare, which are used for the pump connections. They seal the connections between grooved pump valves and the grooved inserts from ProMinent - see Fig. 14.
- In the event that an unflared insert is used (e.g. third party part), an elastomer flat seal must be used - see Fig. 15.

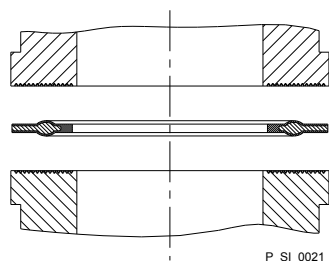

Fig. 14: Moulded composite seals with corrugated insert

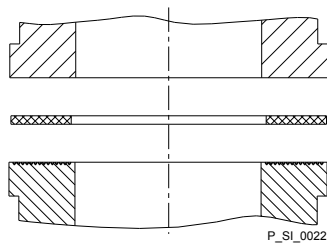

Fig. 15: Elastomer flat seal for a smooth insert

Integral relief valve



CAUTION!

Warning of backflow

Liquid ends, foot valves, back pressure valves, relief valves or spring-loaded injection valves do not constitute absolutely leak-tight sealing elements.

- Use a shut-off valve, a solenoid valve or a vacuum breaker for this purpose.



WARNING!

Product can be dangerously contaminated

Only with the design "Physiologically safety with regard to wetted materials".

If the integral bleed valve or the integral relief valve opens, the feed chemical comes into contact with physiologically harmful seals.

- Do not route feed chemical that escapes from the integral bleed valve or the integral relief valve back into the process.



CAUTION!

Danger due to incorrect use of the integral relief valve

The integral relief valve can only protect the motor and the gear, and then only against impermissible positive pressure that is caused by the metering pump itself. It cannot protect the system against positive pressure.

- Protect the motor and gear of the system against positive pressure using other mechanisms.
- Protect the system against illegal positive pressure using other mechanisms.



CAUTION!

Warning of feed chemical spraying around

If no relief valve was connected to the overflow line, the feed chemical sprays out of the hose connection as soon as the relief valve opens.

- An overflow line must always be connected to the integral relief valve and be fed back to the storage tank or - if required by the regulations - into a special storage tank.



CAUTION!

Danger of cracking

Cracking of the PVT liquid end can occur if a metal overflow line is connected to the relief valve.

- Never connect a metal overflow line to the relief valve.

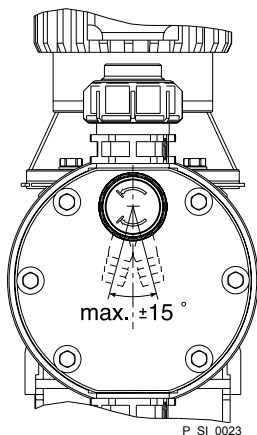

Fig. 16: Permissible alignment of the relief valve



CAUTION!

Danger of the integral relief valve failing

The integral relief valve no longer operates reliably with feed chemicals having a viscosity of greater than 200 mPa s.

- Only use the integral relief valve with feed chemicals having a viscosity up to 200 mPa s.



CAUTION!

Warning against leaks

Feed chemical which remains in the overflow line at the relief valve, can attack the valve or cause it to leak

- Route the overflow line with a continuous slope and moreover with the tube nozzle pointed downwards - see Fig. 16.



If the overflow line is fed into the suction line, the bleed function is blocked.

Therefore lead the overflow line back into the storage tank.



When operating the integral relief valve close to the opening pressure, a minimal overflow into the overflow line can occur.

Diaphragm rupture sensor



CAUTION!

Danger resulting from unnoticed diaphragm rupture

If the pump has been ordered with an electric diaphragm rupture sensor, it still has to be installed.

- Screw the enclosed diaphragm rupture sensor into the liquid end.



CAUTION!

Warning of unnoticed diaphragm rupture

Only above approximately 2 bar system back pressure is a signal generated upon a diaphragm rupture.

- Only rely on the diaphragm rupture sensor at back pressures greater than 2 bar.

7.1 Basic installation notes

Safety notes



CAUTION!

Danger resulting from rupturing hydraulic components

Hydraulic components can rupture if the maximum permissible operating pressure is exceeded.

- Never allow the metering pump to run against a closed shut-off device.
- With metering pumps without integral relief valve: Install a relief valve in the discharge line.



CAUTION!

Hazardous feed chemicals can escape

With hazardous feed chemicals: Hazardous feed chemical can leak out when using conventional bleeding procedures with metering pumps.

- Install a bleed line with a return into the storage tank.

➔ Shorten the return line so that it does not dip into the feed chemical in the storage tank.

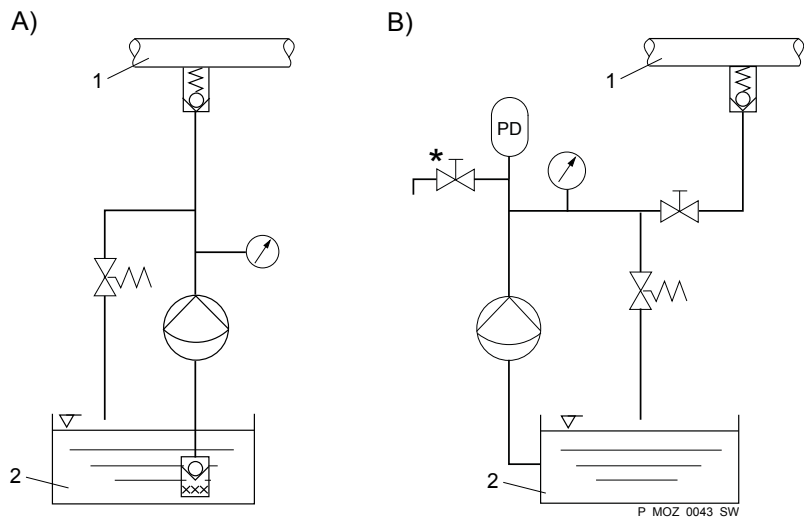

Fig. 17: (A) standard installation, (B) with pulsation damper

- 1 Main line
- 2 Storage tank

Legend for hydraulic diagram

Symbol	Explanation	Symbol	Explanation
	Metering pump		Foot valve with filter meshes
	Injection valve		Level switch
	Multifunctional valve		Manometer

8 Installation, electrical

**WARNING!****EX pumps in areas at risk from explosion**

- Potential-free switches can be evaluated as simple electrical devices (EN 60079-14 or EN 50020).
- Only connect potential-free as well as non-isolating low voltage switch accessories, such as diaphragm rupture indicators, stroke frequency instruments etc., to an intrinsically safe power circuit in areas at risk from explosion.
- If several electrical components are connected together, test and confirm the technical safety of the entire connected system. This can either be in the form of a declaration of conformity from the supplier (ProMinent) for the entire unit or, with the supply of individual components, with the operator's explosion protection document.
- Only motor protection switches, mains switches and fuses permitted for use in areas at risk from explosion in line with the manufacturer's information may be used as electrical components in areas at risk from explosion.
- Note the enclosed documentation for the individual electrical components.

**WARNING!****Danger of electric shock**

Unprofessional installation may lead to electric shocks.

- Provide all shortened cable cores with cable end sleeves.
- Only technically trained personnel are authorised to undertake the electrical installation of the device.

**WARNING!****Danger of electric shock**

In the event of an electrical accident, it must be possible to quickly disconnect the pump, and any electrical ancillaries which may possibly be present, from the mains.

- Install an emergency cut-off switch in the mains supply line to the pump and any electrical ancillaries which may be present or
- Integrate the pump and electrical ancillaries which may be present in the emergency cut-off management of the system and inform personnel of the isolating option.

**WARNING!****Danger of electric shock**

This pump is equipped with a protective earth conductor, to reduce the risk arising from an electric shock.

- Connect the PE conductor to "earth" with a clean and permanent electrical connection.



WARNING!

Danger of electric shock

A mains voltage may exist inside the motor or electrical ancillaries.

- If the housing of the motor or electrical ancillaries has been damaged, you must disconnect it from the mains immediately. The pump must only be returned to service after an authorised repair.

What requires electrical installation?

- Motor
- External fan (optional)
- Stroke control drive (optional)
- Stroke adjusting drive (optional)
- Diaphragm rupture sensor (Option)
- Stroke sensor (optional)
- Pacing relay (option)
- Frequency converter (optional)

Motor

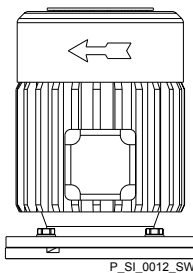

Fig. 18: Direction of rotation of motor



WARNING!

EX pumps in areas at risk from explosion

- Protect drive motors with appropriate motor protection switches. Only use motor protection permitted for this kind of application with Ex"e" motors. (Protection against heating from overloading)
- Ensure that motors are only installed and inspected by a "recognisably trained" skilled operative in areas at risk from explosion.
- Observe the enclosed operating instructions for the Ex motor.



CAUTION!

The motor can be damaged

Provide appropriate motor protection devices (e.g. motor protection switch with thermal overcurrent trip) to protect the motor against overloading.

Fuses do not provide motor protection.



CAUTION!

The pump can be damaged

The pump can be damaged if the motor drives the pump in the wrong direction.

- When connecting the motor, pay attention to the correct direction of rotation indicated by the arrow on the fan cover, as shown in Fig. 18.



Install an electrical isolating device in the mains supply cable, e.g. a mains switch, to be able to switch off the pump independently of the entire installation (e.g. for repair).

1. ➤ Install a motor protection switch, as the motors have no fuse.
2. ➤ Install an emergency cut-off switch or include the motor in the emergency cut-off management plan for the system.
3. ➤ Only connect the motor to the voltage supply using a suitable cable.



- Key motor data can be found on the nameplate.
- The terminal wiring diagram is located in the terminal box.



Motor data sheets, special motors, special motor flanges, external fan, temperature monitoring

- For further information for the motor with identity code specification "S", refer to the motor data sheet in the Appendix. Motor data sheets can be requested for all other motors.
- For motors other than those with identity code specifications "S", "M" or "N": Pay special attention to the operating instructions for the motors.
- Special motors or special motor flanges are possible on request.

External fans



CAUTION!

Provide a separate power supply for the external fan with motors with external fans (identity code specification "R" or "Z").

Variable speed motors with frequency converter

Connect up the motor as per the wiring diagram for the controller, if it is controlled by an electronic control unit (such as direct current motors by a frequency converter).

Stroke length actuators / control drives

Connect the motors as per the enclosed wiring diagram or the wiring diagram on the inside of the housing.



CAUTION!

Only operate stroke length actuators / control drives when the pump is running!

Otherwise they will be damaged.

Diaphragm rupture sensor (Option)



WARNING!

Risk of electric shock

In event of a defect, there is a risk of electric shock when conductive feed chemical are used.

- For safety reasons we recommend connecting to a protective low voltage, e.g. in accordance with EN 60335-1 (SELV).



CAUTION!

Danger resulting from unnoticed diaphragm rupture

If the pump has been ordered with an electric diaphragm rupture sensor, it must also be electrically installed.

- Install the enclosed diaphragm rupture sensor electrically to a suitable monitoring device.

a) Diaphragm rupture sensor with switch contact



- *The cable can be poled as required.*

b) Namur sensor, inherently safe

The monitor / power supply installed by the customer must be able to evaluate the current variations of the Namur sensor for indicating a diaphragm rupture!

Stroke sensor (identity code specification "Stroke sensor": 3)

- ➔ Connect the stroke sensor to a suitable monitoring device according to the technical data provided with the monitoring device and that of the stroke sensor - see chapter "Technical data".

Pacing relay (identity code specification "Stroke sensor": 2)

1. ➔ Install the cable which originates from the pacing relay - see the figure in the chapter entitled "Overview of equipment and control elements": Cable A, left.



The cable polarity is unimportant.

2. ➔ Install the power supply cable to the pacing relay PCB - see the figure in the chapter entitled "Overview of equipment and control elements": Cable B, right.



CAUTION!

Warning of overload

If the current through the relay becomes too high, it can be destroyed by heating.

- Fit a circuit breaker.

Pacing relay terminal output data

Data	Value	Unit
Maximum voltage	24	VDC
Maximum current	100	mA
Closing duration, approx.	100	ms
Service life *	50 x 10 ⁶ (10 V, 10 mA)	Play

* at rated load

The contacts are potential-free.

The pacing relay is a N/O as standard.

Supply voltage for pacing relay PCB

Available supply voltages	Mains supply frequency	Power consumption
230 V AC (180-254 V)	50 / 60 Hz	10 mA (at 230 V, 50 Hz)
115 V AC (90-134 V)	50 / 60 Hz	15 mA (at 115 V, 60 Hz)
24 V DC (20-28 V)	-	10 mA (at 24 V DC)

Heating cartridge

—▶ Install the heating cartridge according to its documentation. It must only be connected to the supplied power supply!

Other units

—▶ Install the other units in line with their documentation.

9 Start up

Safety notes



WARNING!

EX pumps in areas at risk from explosion

- An appropriately skilled operative should check whether the appropriate installation information from the "Installation" chapter has been implemented correctly.



WARNING!

Fire hazard with flammable media

Only with combustible media: These may start to burn when combined with oxygen.

- During filling and draining of the liquid end, an expert must ensure that feed chemical does not come into contact with oxygen.



CAUTION!

Feed chemical could escape

- Check suction and discharge lines and liquid end with valves for leak-tightness and tighten if necessary.
- Check whether the necessary flushing pipes or bleed lines have been connected.



CAUTION!

Prior to commissioning, check that the power end motor and corresponding ancillary equipment is connected in compliance with the regulations.



CAUTION!

When using pumps with speed control, observe the instructions in the frequency converter operating instructions.

Diaphragm rupture sensor



CAUTION!

Danger resulting from unnoticed diaphragm rupture

If the pump has been ordered with an electric diaphragm rupture sensor, it still has to be installed.

- Screw the enclosed diaphragm rupture sensor into the liquid end.



CAUTION!

Warning of unnoticed diaphragm rupture

Only above approximately 2 bar system back pressure is a signal generated upon a diaphragm rupture.

- Only rely on the diaphragm rupture sensor at back pressures greater than 2 bar.

**CAUTION!****Possible environmental and material damage**

In event the red gear bleeding plug is sealed, during operation it prevents any pressure compensation between the drive housing and the surroundings. This ensure that oil can be pushed from the drive housing.

- Remove the gear bleeding plug before commissioning.

Remove the gearbox vent stopper

Before start up pull the red gearbox vent stopper off, see chapter "Overview of equipment and control elements".

Checking the oil level

When the pump is idle, check whether the oil level in the pump is in the middle of the oil level indicator.

This will rule out the pump losing oil and suffering damage.

Checking the direction of rotation

When commissioning the unit, check whether the drive motor is rotating correctly - check this against the arrow on the motor housing or the diagram in the chapter entitled "Electrical Installation."

Using the integral relief valve**CAUTION!****Danger due to incorrect use of the integral relief valve**

The integral relief valve can only protect the motor and the gear, and then only against impermissible positive pressure that is caused by the metering pump itself. It cannot protect the system against positive pressure.

- Protect the motor and gear of the system against positive pressure using other mechanisms.
- Protect the system against illegal positive pressure using other mechanisms.

**CAUTION!****Danger of the integral relief valve failing**

The integral relief valve no longer operates reliably with feed chemicals having a viscosity of greater than 200 mPa s.

- Only use the integral relief valve with feed chemicals having a viscosity up to 200 mPa s.

Priming against pressure

1. ➤ Hydraulically isolate the discharge line from the pump using an isolation device.
2. ➤ Turn the rotary dial on the integral relief valve in a counter-clockwise direction as far as the "open" stop.
 - ⇒ The excess pressure escapes through the hose connector.
3. ➤ Run the pump until the feed chemical coming out of the hose connector is free from bubbles.
4. ➤ Turn the rotary dial on the integral relief valve in a clockwise direction up to the "close" stop.
 - ⇒ **The pump can be started.**



When operating the integral relief valve close to the opening pressure, a minimal overflow into the overflow line can occur.

Adjusting the stroke length



Only adjust the stroke length when the pump is running. This is easier and also better for the pump.

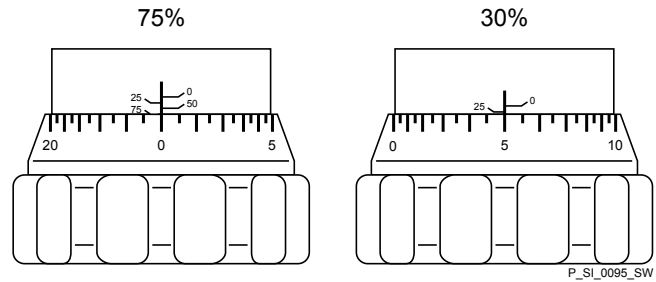

Fig. 19: Adjusting the stroke length

- 100 % = 4 rotations
- 25 % = 1 rotation
- 0.5 % = 1 scale mark on stroke adjustment dial

10 Maintenance

Safety notes



WARNING!

EX pumps in areas at risk from explosion

- Ensure correct operation in general, particularly of the power end and bearing, by regular monitoring (for leaks, noises, temperatures, smell ...).
- Do not allow the pump to become hot due to a lack of oil. Regularly check lubricated metering pumps for the existence of lubricant, for example by checking the liquid level, visual leak control etc. If oil is leaking, examine the leakage point immediately and eliminate the cause.
- Check the correct operation of the relief valve downstream of the pump. In premises at risk from explosion, the relief valve should prevent the gear from becoming overloaded and becoming hot.
- When cleaning plastic components, ensure that no electrostatic charges are generated by excessive friction. - see warning label.
- Replace wear parts, such as bearings, as soon as unacceptable wear is detected. (The nominal service life cannot be calculated with lubricated bearings).
- Use genuine spare parts for replacement.
- Only perform tests and repairs in compliance with DIN EN IEC 60079-17 and only permit "experienced personnel who have the requisite knowledge" to perform the work.
- These measures constitute the minimum protective measurements stipulated by ProMinent. It is the duty of the operator to eliminate any other dangers identified by appropriate measures.



WARNING!

Fire hazard with flammable media

Only with combustible media: These may start to burn when combined with oxygen.

- During filling and draining of the liquid end, an expert must ensure that feed chemical does not come into contact with oxygen.



WARNING!

It is mandatory that you read the safety information and specifications in the "Storage, Transport and Unpacking" chapter prior to shipping the pump.



CAUTION!

Warning of feed chemical spraying around

Feed chemical can spray out of the hydraulic components if they are manipulated or opened due to pressure in the liquid end and adjacent parts of the system.

- Disconnect the pump from the mains power supply and ensure that it cannot be switched on again by unauthorised persons.
- Depressurise the system before commencing any work on hydraulic parts.



WARNING!

Warning of dangerous or unknown feed chemical

Should a dangerous or unknown feed chemical be used: It may escape from the hydraulic components when working on the pump.

- Take appropriate protective measures before working on the pump (e.g. safety glasses, safety gloves, ...). Observe the safety data sheet for the feed chemical.
- Drain and flush the liquid end before working on the pump.



WARNING!

Danger of an electric shock

When working on the motor or electrical auxiliary equipment, there is a danger of an electric shock.

- Before working on the motor, take note of the safety instructions in its operating instructions!
- Should external fans, servomotors or other auxiliary equipment be installed, these should also be disconnected and checked that they are voltage free.



Third party spare parts for the pumps may lead to problems when pumping.

- Use only original spare parts.
- Use the correct spare parts kits. In case of doubt, refer to the exploded views and ordering information in the appendix.

Standard liquid ends:

Interval	Maintenance work	Personnel
After approx. 5,000 operating hours	Change gear oil - refer to "Changing gear oil" in this chapter.	Instructed personnel
Quarterly	Check the oil level.	
Quarterly*	<ul style="list-style-type: none"> ■ Check that the metering lines are fixed firmly to the liquid end. ■ Check that the suction valve and discharge valve are correctly seated. ■ Check that the dosing head screws are tight. ■ Check the condition of the metering diaphragm - see ↗ 'Check the condition of the metering diaphragm' on page 32. ■ Check that the flow is correct: Allow the pump to prime briefly. ■ Check that the electrical connections are intact. 	Technical personnel

* Under normal loading (approx. 30 % of continuous operation).

Under heavy loading (e.g. continuous operation): shorter intervals.

Check the condition of the metering diaphragm

The diaphragm is a wearing part, the service life of which is dependent upon the following parameters:

- System back pressure
- Operating temperature
- Feed chemical properties

When using abrasive feed chemicals, the diaphragm service life is reduced. In such cases, more frequent checking of the diaphragm is recommended.

Tightening torques

Data	Value	Unit
Tightening torques for dosing head screws:	4.5 ... 5.0	Nm

Liquid ends with integral relief valve



WARNING!

Warning of eye injuries

When opening the relief valve, a spring under high tension can jump out.

- Wear protective glasses.

Changing gear oil

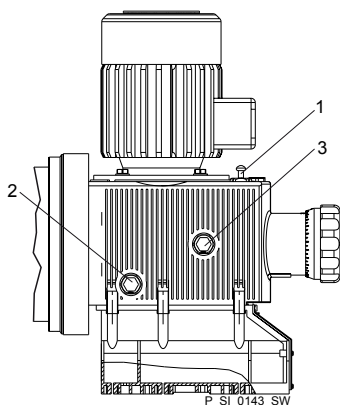

Fig. 20

Draining gear oil

1. ➔ Remove the vent screw (1).
2. ➔ Place an oil trough under the oil drain plug (2).
3. ➔ Unscrew the oil drain plug (2) from the power end housing.
4. ➔ Allow the gear oil to run out of the power end.
5. ➔ Screw in the oil drain plug (2) with a new seal.

Filling with gear oil

Prerequisites: Gear oil according to the "Ordering information" chapter is available.

1. ➔ Slowly pour gear oil through the vent screw (1) opening until the oil inspection window (3) is half covered.
2. ➔ Allow the pump to run for 1... 2 minutes
3. ➔ Replace the vent screw (1).

11 Repairs

Safety notes



WARNING!

EX pumps in areas at risk from explosion

- Generally check the proper operation of the system, particularly of the power end and bearings, by regular monitoring (for leaks, noises, temperatures, smell).



WARNING!

Fire hazard with flammable media

Only with combustible media: These may start to burn when combined with oxygen.

- During filling and draining of the liquid end, an expert must ensure that feed chemical does not come into contact with oxygen.



WARNING!

It is mandatory that you read the safety information and specifications in the "Storage, Transport and Unpacking" chapter prior to shipping the pump.



CAUTION!

Warning of feed chemical spraying around

Feed chemical can spray out of the hydraulic components if they are manipulated or opened due to pressure in the liquid end and adjacent parts of the system.

- Disconnect the pump from the mains power supply and ensure that it cannot be switched on again by unauthorised persons.
- Depressurise the system before commencing any work on hydraulic parts.



WARNING!

Warning of dangerous or unknown feed chemical

Should a dangerous or unknown feed chemical be used: It may escape from the hydraulic components when working on the pump.

- Take appropriate protective measures before working on the pump (e.g. safety glasses, safety gloves, ...). Observe the safety data sheet for the feed chemical.
- Drain and flush the liquid end before working on the pump.

11.1 Cleaning valves



Unsuitable spare parts for the valves may lead to problems for the pumps.

- Only use new components that are especially adapted to fit your valve (both in terms of shape and chemical resistance).
- Use the correct spare parts kits. In case of doubt, refer to the exploded views and ordering information in the appendix.

Only with the "Physiologically safe" design:



WARNING!

Product can be dangerously contaminated

Only use the spare parts from the "Physiologically safe" spare parts kits.

Personnel: ■ Technical personnel

Repairing ball valves



CAUTION!

Warning of personal injury and material damage

Feed chemical may escape from the liquid end, for example, if ball valves not repaired correctly.

- Only use new components which fit your valve - both in terms of shape and chemical resistance!
- Note the flow direction of the discharge and suction connectors when fitting the valve.



CAUTION!

Warning of feed chemical spraying around

PTFE seals, which have already been used / compressed, can no longer reliably seal a hydraulic connection.

- New, unused PTFE seals must always be used.

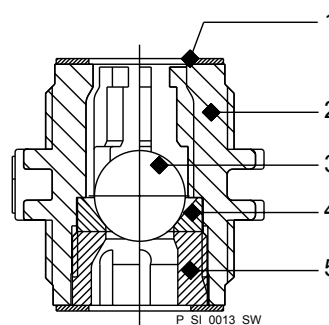

Fig. 21: Simple cross-section through ball valve

- 1 Flat seal
- 2 Valve body
- 3 Valve ball
- 4 Valve seat
- 5 Valve cap

11.2 Replacing the diaphragm



Third party spare parts for the pumps may lead to problems when pumping.

- *Use only original spare parts.*
- *Use the correct spare parts kits. In case of doubt, refer to the exploded views and ordering information in the appendix.*

Personnel: ■ Technical personnel

Requirements:

- If necessary take protective measures.
 - Adhere to the safety data sheet for the feed chemical.
 - Ensure that the system is at atmospheric pressure.
1. Drain the liquid end: Place the liquid end on its head and allow the feed chemical to run out; flush out with a suitable medium; flush the liquid end thoroughly when using hazardous feed chemicals!
 2. With the pump running, move the stroke adjustment dial to the stop at 0 % stroke length.
 - ⇒ The drive axle is now difficult to turn.
 3. Switch off the pump.
 4. Unscrew the hydraulic connectors on the discharge and suction side.
 5. Unscrew the diaphragm rupture sensor from the dosing head.
 6. Remove the 6 screws on the dosing head.
 7. Remove the dosing head.
 8. Check the condition of the diaphragm rupture sensor - see  'Checking the condition of the diaphragm rupture sensor' on page 38.
 9. Loosen the diaphragm from the drive axle with a gentle backwards turn in the anti-clockwise direction.
 10. Completely unscrew the diaphragm from the drive axle.
 11. Tentatively screw the new diaphragm anticlockwise up to the stop on the drive axle.
 - ⇒ The diaphragm now is now seated against the stop of the thread while the diaphragm flap is within the tolerance range.

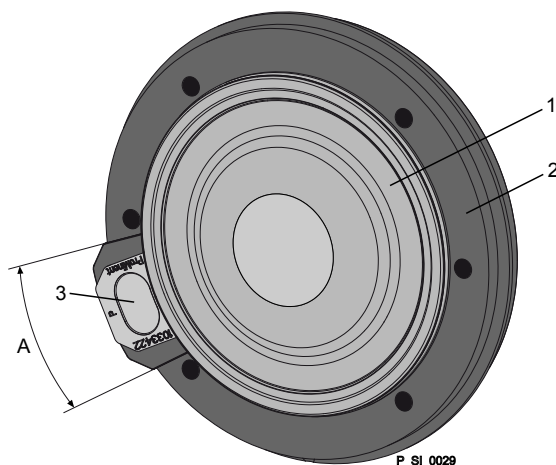

Fig. 22: Tolerance range of the flap on the backplate

- 1 Diaphragm
- 2 Backplate
- 3 Flap
- A Tolerance range

12. Should this not work, remove dirt or swarf out of the thread and screw the diaphragm correctly onto the drive axle this time.
 - ⇒ If this is still unsuccessful, contact ProMinent-ProMaqua customer service.
13. Place the dosing head with the screws onto the diaphragm - the suction connector must be pointing downwards in the pump's fitting position.
14. Tighten the screws gently to start with.
15. Screw the diaphragm rupture sensor into the dosing head.
16. Start up the pump and adjust the stroke length to 100 %.
17. Stop the pump and tighten the screws crosswise. Tightening torque - see *Tightening torques* on page 33.
18. Start the pump and at maximum pressure, check for leaks.



CAUTION!

Warning of escaping feed chemical

The liquid end may leak should it not be possible to check the tightening torque of the screws.

- Check the tightening torque of the screws after 24 hours of operation!
- With PP, PC and TT dosing heads also re-check the tightening torques quarterly!

Checking the condition of the diaphragm rupture sensor

1. ➤ If the inside of the diaphragm rupture sensor has become damp or dirt has penetrated it: replace.

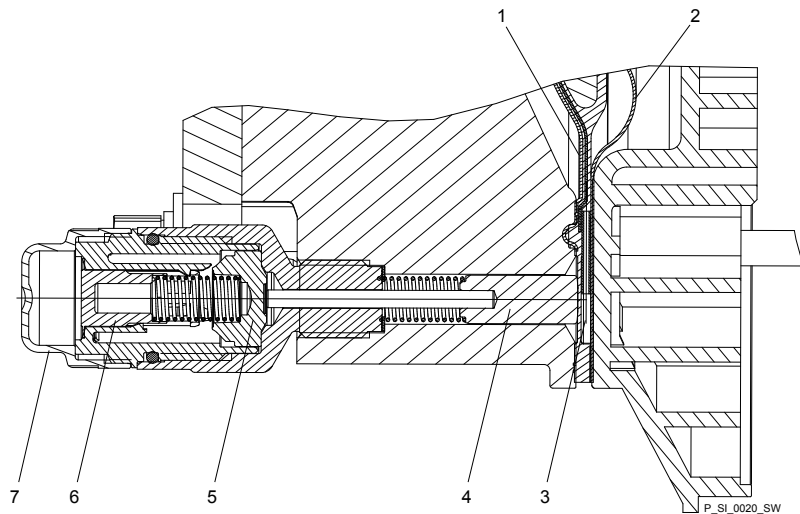

Fig. 23: Section through the Sigma diaphragm rupture warning system ("Visual break indicator" version)

- 1 Working layer (≙ operating diaphragm)
- 2 Safety layer (≙ safety diaphragm)
- 3 Flap
- 4 Piston
- 5 Diaphragm rupture sensor
- 6 Cylinder, red
- 7 Cover, transparent

2. ➤ If the piston of the diaphragm rupture sensor - see Fig. 23, item 4 - should have become dirty or damp, clean both it and the hole in which it runs.
3. ➤ Check whether it can move freely in the hole.
4. ➤ Refit the clean diaphragm rupture sensor with the clean piston.
5. ➤ Test the diaphragm rupture sensor.

Optical diaphragm rupture sensor

1. ➤ Unscrew the transparent cover from the diaphragm rupture sensor.
2. ➤ Press the red cylinder into the diaphragm rupture sensor until it engages.
3. ➤ Press the piston on the other side of the diaphragm rupture sensor with a blunt, smooth object into the dosing head (approximately 4 mm) until it triggers.



CAUTION!

Feed chemical may escape

If the expandable flap of the diaphragm is damaged, then feed chemical can escape when there is a diaphragm rupture.

The piston must not be scratched, it must remain completely smooth so that during operation it does not damage the expandable flap of the diaphragm.

4. ➤ Press the red cylinder into the diaphragm rupture sensor again and repeat the test.
5. ➤ If it does not trigger both times, replace the membrane rupture sensor.

6. ➔ After a successful test, screw the transparent cover onto the diaphragm rupture sensor and then continue at the top by fitting the diaphragm.

Electrical diaphragm rupture sensor

1. ➔ Press the piston of the diaphragm rupture sensor with a blunt, smooth object into the dosing head (approximately 4 mm) until the monitor triggers alarm.



CAUTION!

Feed chemical may escape

If the expandable flap of the diaphragm is damaged, then feed chemical can escape when there is a diaphragm rupture.

The piston must not be scratched, it must remain completely smooth so that during operation it does not damage the expandable flap of the diaphragm.

2. ➔ Repeat the test.
3. ➔ If the monitor does not trigger an alarm both times, replace the membrane rupture sensor.
4. ➔ After a successful test, continue at the top by fitting the diaphragm.

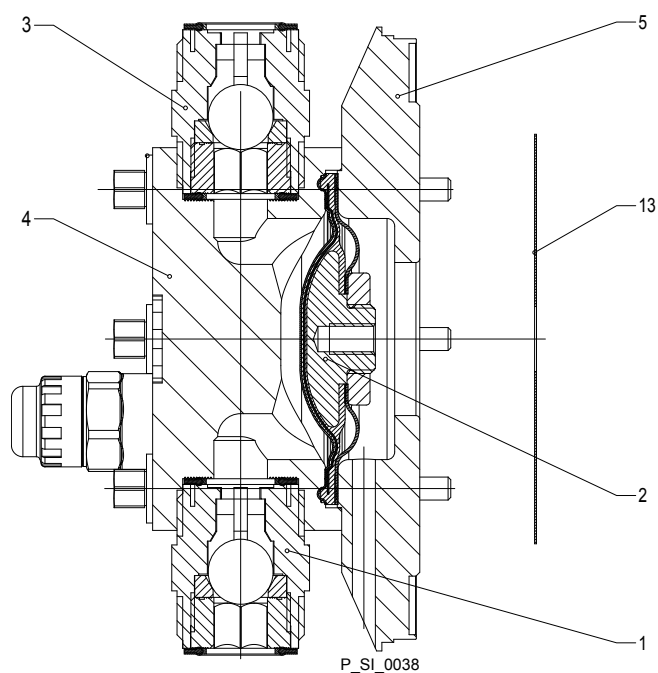

Fig. 24: Cross-section through the liquid end

- 1 Suction valve
- 2 Diaphragm
- 3 Discharge valve
- 4 Dosing head
- 5 Backplate
- 13 Safety diaphragm

12 Troubleshooting

Safety notes



WARNING!

EX pumps in areas at risk from explosion

- Ensure correct operation in general (no leaks, unusual noises, high temperatures, unusual smells etc.), particularly of the power end and bearings.
- Do not allow the pump to become hot due to a lack of oil! If oil is escaping, investigate the leak immediately and eliminate the cause.
- When cleaning plastic parts, ensure that excessive friction does not cause electrical charges - see warning label.
- Replace wear parts, such as bearings, as soon as unacceptable wear is detected. (The nominal service life cannot be calculated with lubricated bearings).
- Use genuine spare parts for replacement.
- Only perform tests and repairs in compliance with DIN EN IEC 60079-17 and only permit "experienced personnel who have the requisite knowledge" to perform the work.



WARNING!

Fire hazard with flammable media

Only with combustible media: These may start to burn when combined with oxygen.

- During filling and draining of the liquid end, an expert must ensure that feed chemical does not come into contact with oxygen.



WARNING!

Danger of an electric shock

Personnel working on electrical parts can be electrocuted if all electrical lines carrying current have not been disconnected.

- Disconnect the supply cable before working on the motor and prevent it from being reconnected accidentally.
- Any separately driven fans, servo motors, speed controllers or diaphragm rupture sensors fitted should also be disconnected.
- Check that the supply cables are de-energised.



WARNING!

Warning of dangerous or unknown feed chemical

Should a dangerous or unknown feed chemical be used: It may escape from the hydraulic components when working on the pump.

- Take appropriate protective measures before working on the pump (e.g. safety glasses, safety gloves, ...). Observe the safety data sheet for the feed chemical.
- Drain and flush the liquid end before working on the pump.



CAUTION!

Warning of feed chemical spraying around

Feed chemical can spray out of the hydraulic components if they are manipulated or opened due to pressure in the liquid end and adjacent parts of the system.

- Disconnect the pump from the mains power supply and ensure that it cannot be switched on again by unauthorised persons.
- Depressurise the system before commencing any work on hydraulic parts.

Tasks

Fault description	Cause	Remedy	Personnel
Pump does not prime in spite of full stroke motion and bleeding.	The valves are dirty or worn.	Repair the valves - see chapter entitled "Repair".	Technical personnel
	The feed chemical has particles larger than 0.3 mm.	Install a suitable filter in the suction line.	Technical personnel
Pump does not reach high pressure rates.	The valves are dirty or worn.	Repair the valves - see chapter entitled "Repair".	Technical personnel
	The motor is wired incorrectly.	1. Check the mains voltage and mains frequency. 2. Wire the motor correctly.	Electrician
	The mains voltage has failed.	Eliminate the cause.	Electrician
Fluid is escaping from the backplate.	The dosing head screws are no longer tight enough.	Tighten the screws crosswise to the specified tightening torque.	Technical personnel
	The diaphragm leaks.**	Replace the diaphragm - refer to the "Repair" chapter.	Technical personnel
Large leaks occur at the relief valve.	The ball or ball seat are dirty or worn.	Clean or replace the ball and ball seat.	Technical personnel
The diaphragm rupture sensor has triggered.	The operating diaphragm has ruptured.**	Replace the diaphragm - refer to the "Repair" chapter.	Technical personnel
The drive motor is very hot.	The discharge line is seriously constricted.	Rectify any constriction of the discharge line.	Technical personnel
All other faults.	Other causes.	Call the ProMinent customer services.	

* If necessary use the cross-section drawing of the integral relief valve in the "Functional Description" chapter.



WARNING!

Warning of eye injuries

When opening the relief valve, a spring under high tension can jump out.

- Wear protective glasses.

**



WARNING!

Warning of escaping feed chemical

When dosing combustible feed chemicals or in hazardous locations, under no circumstances must the second diaphragm also rupture.

- If the pump diaphragm rupture sensor triggers, stop the pump immediately and only operate once a new multi-layer safety diaphragm has been fitted.



CAUTION!

Warning of inaccurate dosing

Once the operating membrane has ruptured, precise dosing of the pump can no longer be guaranteed.

- Do not continue to use the pump for critical process dosing.
- For uncritical processes, the pump can continue to be operated for some time after the break in emergency service mode at full operating pressure and free from leaks up until replacement of the diaphragm.

Only with the "Physiologically safe" design:



WARNING!

Following a rupture of the diaphragm, the pump loses its FDA approval until the diaphragm has been replaced.

13 Decommissioning

Decommissioning

**WARNING!****Fire hazard with flammable media**

Only with combustible media: These may start to burn when combined with oxygen.

- During filling and draining of the liquid end, an expert must ensure that feed chemical does not come into contact with oxygen.

**WARNING!****Danger of an electric shock**

When working on the motor or electrical auxiliary equipment, there is a danger of an electric shock.

- Before working on the motor, take note of the safety instructions in its operating instructions!
- Should external fans, servomotors or other auxiliary equipment be installed, these should also be disconnected and checked that they are voltage free.

**WARNING!****Danger from chemical residue**

There is normally chemical residue in the liquid end and on the housing after operation. This chemical residue could be hazardous to people.

- It is mandatory that the safety notes relating to the "Storage, Transport and Unpacking" chapter are read before shipping or transporting the unit.
- Thoroughly clean the liquid end and the housing of chemicals and dirt. Adhere to the safety data sheet for the feed chemical.

**WARNING!****Warning of dangerous or unknown feed chemical**

Should a dangerous or unknown feed chemical be used: It may escape from the hydraulic components when working on the pump.

- Take appropriate protective measures before working on the pump (e.g. safety glasses, safety gloves, ...). Observe the safety data sheet for the feed chemical.
- Drain and flush the liquid end before working on the pump.

**CAUTION!****Warning of feed chemical spraying around**

Feed chemical can spray out of the hydraulic components if they are manipulated or opened due to pressure in the liquid end and adjacent parts of the system.

- Disconnect the pump from the mains power supply and ensure that it cannot be switched on again by unauthorised persons.
- Depressurise the system before commencing any work on hydraulic parts.



WARNING!

Warning of eye injuries

When opening the relief valve, a spring under high tension can jump out.

- Wear protective glasses.



CAUTION!

Danger of damage to the device

The device can be damaged by incorrect and improper storage or transportation.

- Take into account the information in the "Storage, Transport and Unpacking" chapter if the system is decommissioned for a temporary period.

(Temporary) decommissioning

1. ➤ Disconnect the pump from the mains power supply.
2. ➤ Depressurise and bleed the hydraulic system around the pump.
3. ➤ Drain the liquid end by turning the pump upside down and allowing the feed chemical to run out.
4. ➤ Flush the liquid end with a suitable medium - Observe the safety data sheet! Flush the dosing head thoroughly when using hazardous feed chemicals!
5. ➤ Possible additional work - see chapter "Storage, Transport and Unpacking".

Final decommissioning

- Also drain the gear oil - refer to the chapter entitled "Maintenance".

Disposal



CAUTION!

Environmental hazard due to incorrect disposal

- Note the local guidelines currently applicable in your country, particularly in regard to electronic waste!



CAUTION!

Environmental hazard due to gear oil

The pump contains gear oil, which can cause damage to the environment.

- Drain the gear oil from the pump.
- Note the local guidelines currently applicable in your country!

14 Technical data

Only for "M - modified" design:



WARNING!

Risk of personal injuries

Please observe the "Supplement for modified version" at the end of the chapter!

It replaces and supplements the technical data!

14.1 Performance data

S2Ba under 50 Hz operation

Type	Minimum pump capacity at maximum back pressure			Maximum stroke rate	Suction lift	Permissible priming pressure, suction side	Connector size
	bar	l/h	ml/stroke				
16050 PVT	10	50	11.4	73	7	3	1" - 15
16050 SST	16	47	11.4	73	7	3	1" - 15
16090 PVT	10	88	11.4	132	7	3	1" - 15
16090 SST	16	82	11.4	132	7	3	1" - 15
16130 PVT	10	135	10.9	198	7	3	1" - 15
16130 SST	16	124	10.9	198	7	3	1" - 15
07120 PVT	7	126	27.4	73	5	1	20*
07120 SST	7	126	27.4	73	5	1	20*
07220 PVT	7	220	27.7	132	5	1	20*
07220 SST	7	220	27.7	132	5	1	20*
04350 PVT	4	350	29.4	198	5	1	20*
04350 SST	4	350	29.4	198	5	1	20*

All figures refer to water at 20 °C.

The suction lift applies to filled suction line and filled liquid end - when installed correctly.



* For Sigma types 07120, 07220 and 04350 the valves in the dosing head are of type DN 25 (G1 1/2). As for these types of pipes, DN 20 is generally sufficient (see technical data, suction/discharge side connector), the connector parts that can be ordered under the identity code (e.g. inserts) are already reduced to DN 20, i.e. piping and accessories can be installed in DN 20.

Technical data

S2Ba under 60 Hz operation

Type	Minimum pump capacity at maximum back pressure				Maximum stroke rate	Suction lift	Permissible priming pressure, suction side	Connector size
	bar	psi	l/h	gph				
16050 PVT	10	145	60	15.9	87	7	3	1" - 15
16050 SST	16	232	56	14.8	87	7	3	1" - 15
16090 PVT	10	145	106	27.8	158	7	3	1" - 15
16090 SST	16	232	98	26.0	158	7	3	1" - 15
16130 PVT	10	145	156	41.0	238	7	3	1" - 15
16130 SST	16	232	148	39.2	238	7	3	1" - 15
07120 PVT	7	102	150	39.7	87	5	1	1 1/2" - 25*
07120 SST	7	102	150	39.7	87	5	1	1 1/2" - 25*
07220 PVT	7	102	264	69.7	158	5	1	1 1/2" - 25*
07220 SST	7	102	264	69.7	158	5	1	1 1/2" - 25*
04350 PVT	4	58	420	108.0	238	5	1	1 1/2" - 25*
04350 SST	4	58	420	108.0	238	5	1	1 1/2" - 25*

All figures refer to water at 20 °C.

The suction lift applies to filled suction line and filled liquid end - when installed correctly.



* For Sigma types 07120, 07220 and 04350 the valves in the dosing head are of type DN 25 (G1 1/2). As for these types of pipes, DN 20 is generally sufficient (see technical data, suction/discharge side connector), the connector parts that can be ordered under the identity code (e.g. inserts) are already reduced to DN 20, i.e. piping and accessories can be installed in DN 20.

Precision

Data	Value	Unit
Reproducibility	±2	% *

* - when installed correctly, under constant conditions, at least 30 % stroke length and water at 20 °C

14.2 Shipping weight

Types	Material version	Shipping weight
		kg
16050 ... 16130	PVT	15
	SST	20

Types	Material version	Shipping weight
		kg
07120 ... 04350	PVT	16
	SST	24

14.3 Wetted materials

Material version	Liquid end	Suction/pressure connector	Seals* / ball seat	Balls	Springs	Integral relief valve
PVT	PVDF	PVDF	PTFE/PTFE	Ceramic / glass **	Hastelloy C	PVDF/FPM or EPDM
SST	Stainless steel 1.4404	Stainless steel 1.4581	PTFE/PTFE	Stainless steel 1.4404	Hastelloy C	Stainless steel/FPM or EPDM

* Metering diaphragm is PTFE coated

** Types 07120, 07220, 04350

14.4 Ambient conditions

14.4.1 Ambient temperatures

Pump, compl.

Data	Value	Unit
Storage and transport temperature	-10 ... +50	°C
Ambient temperature in operation (drive + motor):	-10 ... +45	°C

14.4.2 Media temperatures

PVT liquid end

Data	Value	Unit
Max. temperature long-term at max. operating pressure	65	°C
Max. temperature for 15 min at max. 2 bar	100	°C
Minimum temperature	-10	°C

SST liquid end

Data	Value	Unit
Max. temperature long-term at max. operating pressure	90	°C
Max. temperature for 15 min at max. 2 bar	120	°C
Minimum temperature	-10	°C

14.4.3 Air humidity

Air humidity

Data	Value	Unit
Maximum air humidity *:	92	% rel. humidity

* non-condensing

14.5 Motor data

Electrical data

For motor data - refer to the nameplate.



Motor data sheets, special motors, special motor flanges, external fan, temperature monitoring

- For further information for the motor with identity code specification "S", refer to the motor data sheet in the Appendix. Motor data sheets can be requested for all other motors.
- For motors other than those with identity code specifications "S", "M" or "N": Pay special attention to the operating instructions for the motors.
- Special motors or special motor flanges are possible on request.

14.6 Stroke actuator

Voltage	Mains supply frequency	Capacity
230 V ±10 %	50/60 Hz	11.7 W.
115 V ±10 %	60 Hz.	11.7 W.

14.7 Stroke control drive

Voltage	Mains supply frequency	Capacity
230 V ±10 %	50/60 Hz	6.5 W
115 V ±10 %	60 Hz	6.5 W

14.8 Diaphragm rupture sensor



Install the sensor according to the chapter "Installation, electrical".

a) Contact (Standard for identity code specification "Displacement body": A)

Contact loading, max.

at voltage	Maximum current
30 V DC	1 A.

The diaphragm rupture sensor is an NC.

 – For safety reasons we recommend connecting to a protective low voltage, e.g. in accordance with EN 60335-1 (SELV).
 – The cable can be connected as required.

a) Namur sensor (for identity code specification "Displacement body": A)

5–25 V DC, in accordance with Namur or DIN 60947-5-6, potential-free design.

Data	Value	Unit
Nominal voltage *	8	VDC
Power consumption - active surface uncovered	> 3	mA
Power consumption - active surface covered	< 1	mA
Rated switching distance	1.5	mm

* Ri ~ 1 kΩ

Cable colour	Polarity
blue	-
brown	+

14.9 Stroke sensor "Sigma"

 Install the sensor according to the chapter "Installation, electrical".

a) Pacing relay (stroke sensor with ...) (Identity code specification "Stroke sensor": 2)

For more information, see "Pacing relay" in the "Relay" chapter.

Technical data

b) Namur sensor (identity code specification "Stroke sensor": 3)

5–25 V DC, in accordance with Namur or DIN 60947-5-6, potential-free design.

Data	Value	Unit
Nominal voltage *	8	VDC
Power consumption - active surface uncovered	> 3	mA
Power consumption - active surface covered	< 1	mA
Rated switching distance	1.5	mm

* Ri ~ 1 kΩ

Cable colour	Polarity
blue	-
brown	+

14.10 Relay



The electrical data for the relay are contained in the chapter "Installation, electrical".

14.11 Gear oil

Manufacturer	Name	Viscosity class (ISO 3442)	Part no.	Oil volume, supplied	Oil volume, needed
Mobil	Mobil Gear 634 *	VG 460	1004542	1.0 l	0.5 l

* or comparative gear oil

14.12 Sound pressure level

Sound pressure level

Sound pressure level LpA < 70 dB according to EN ISO 20361 at maximum stroke length, maximum stroke rate, maximum back pressure (water)

14.13 Supplementary information for modified versions

(With identity code specification "Version": "M" - "modified")

Technical data

Technical data of pumps in the modified version can deviate from those of the standard pumps. They can be queried by stating the details of the serial number.

During operation with an automatic stroke length adjustment control together with a variable speed motor, the stroke rate must not fall below 30 strokes / min. Otherwise technical problems occur, because the mechanical resistance of the stroke adjustment spindle becomes too high.

motor

The motor data sheets for the modified version are valid. They may deviate from the standard motor data sheets.

Spare parts

With a modified version, it is absolutely necessary to specify the details of the serial number requesting and ordering the spare and replacement parts.

15 Diagrams for setting the metering capacity

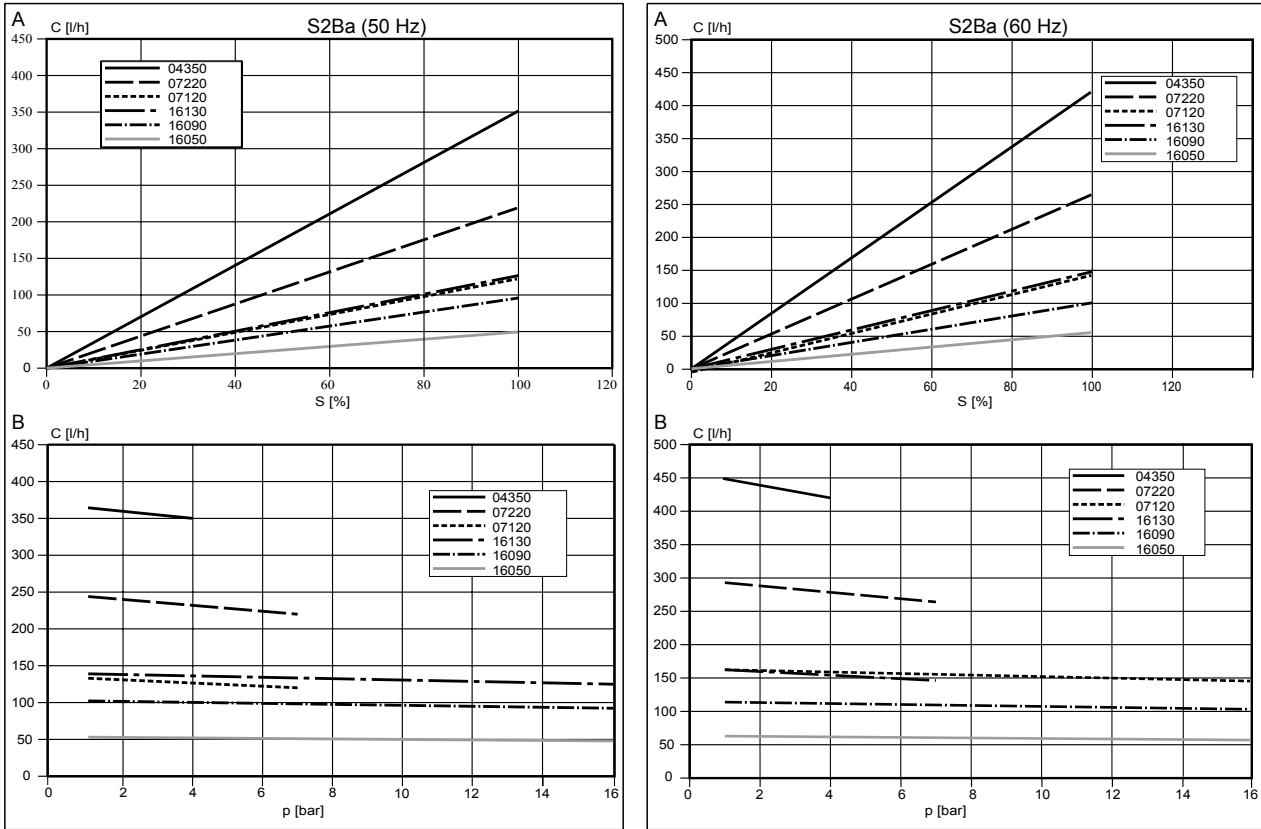
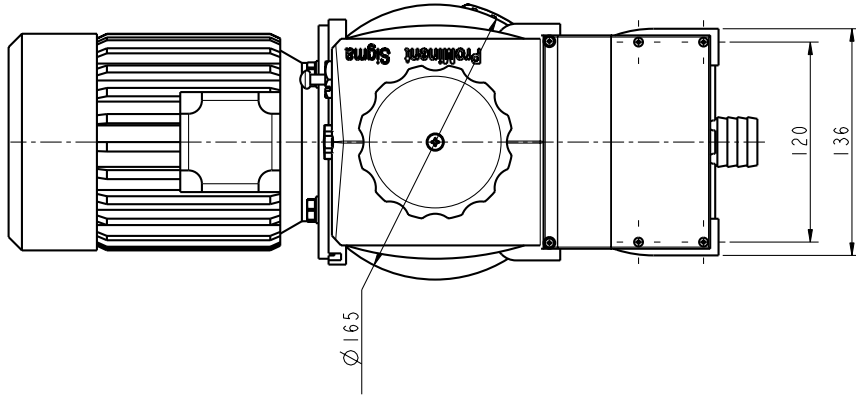

Fig. 25: A) Capacity C at minimum back pressure dependent on the stroke length s. B) Capacity C dependent on the back pressure p.

16 Dimensional drawings



- *Compare the dimensions on the dimension sheet and pump.*
- *All dimensions are in mm.*



Schlauchfülle ÜV d16 S mit Gewinde DIN ISO 228-G3/4 A
 tube nozzle sv. d16 S with Thread DIN ISO 228-G3/4 A

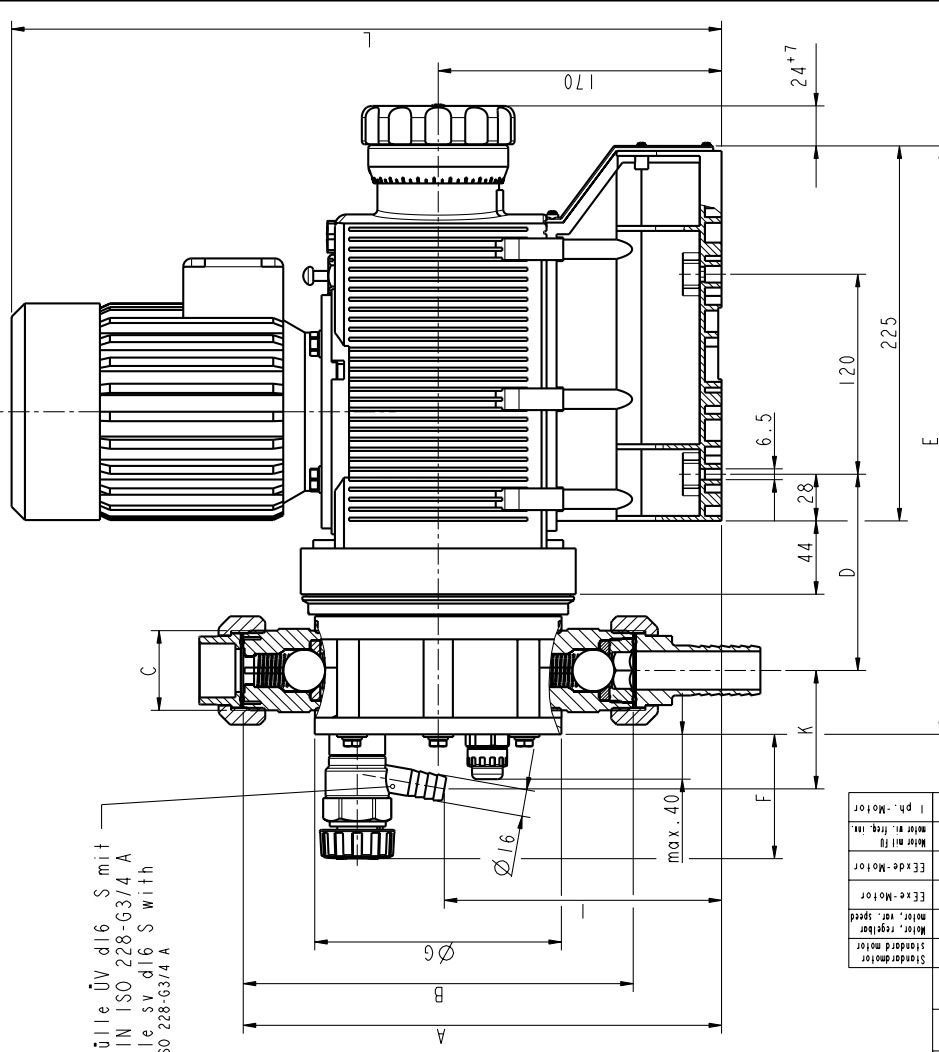

Standardmotor	L	426
Motor, regelbar	L	523
Motor, regelbar, speed	L	472
Exec-Motor	L	448
Exec-Motor	L	644
Motor mit freigegeb. Ix	L	427
Ph.-Motor	L	

Typ	Anschluß connection	A		B		C		D		E		F		Ø G		I		K		L	
		DN 25	287	234	G 1	172	A	118	353	75	156	166	71								
Sigma 04350, 07120, PVT 07220	DN 25	287	234	G 1	172	A	118	353	75	156	166	71									
Sigma 04350, 07120, SST	DN 25	287	233	G 1	172	A	118	345	88	159	140	60									
Sigma 12050, 12090, 12130, 16050, 16090, 16130, PVT	DN 15	251	162	G 1	A	111	341	72	122	148	63										
Sigma 12050, 12090, 12130, 16050, 16090, 16130, SST	DN 15	251	162	G 1	A	110	330	88	122	122	53										

Werkstoff material	Bezeichnung/description	
	Maßblatt S2Ba	
	dimension drawing S2Ba	
	Zücht.-Nr./drawing no.	Blatt
	61_01-101_00-27-73	1
		3
		Bl.

Schutzrechte nach DIN34 beachten Copyright reserved

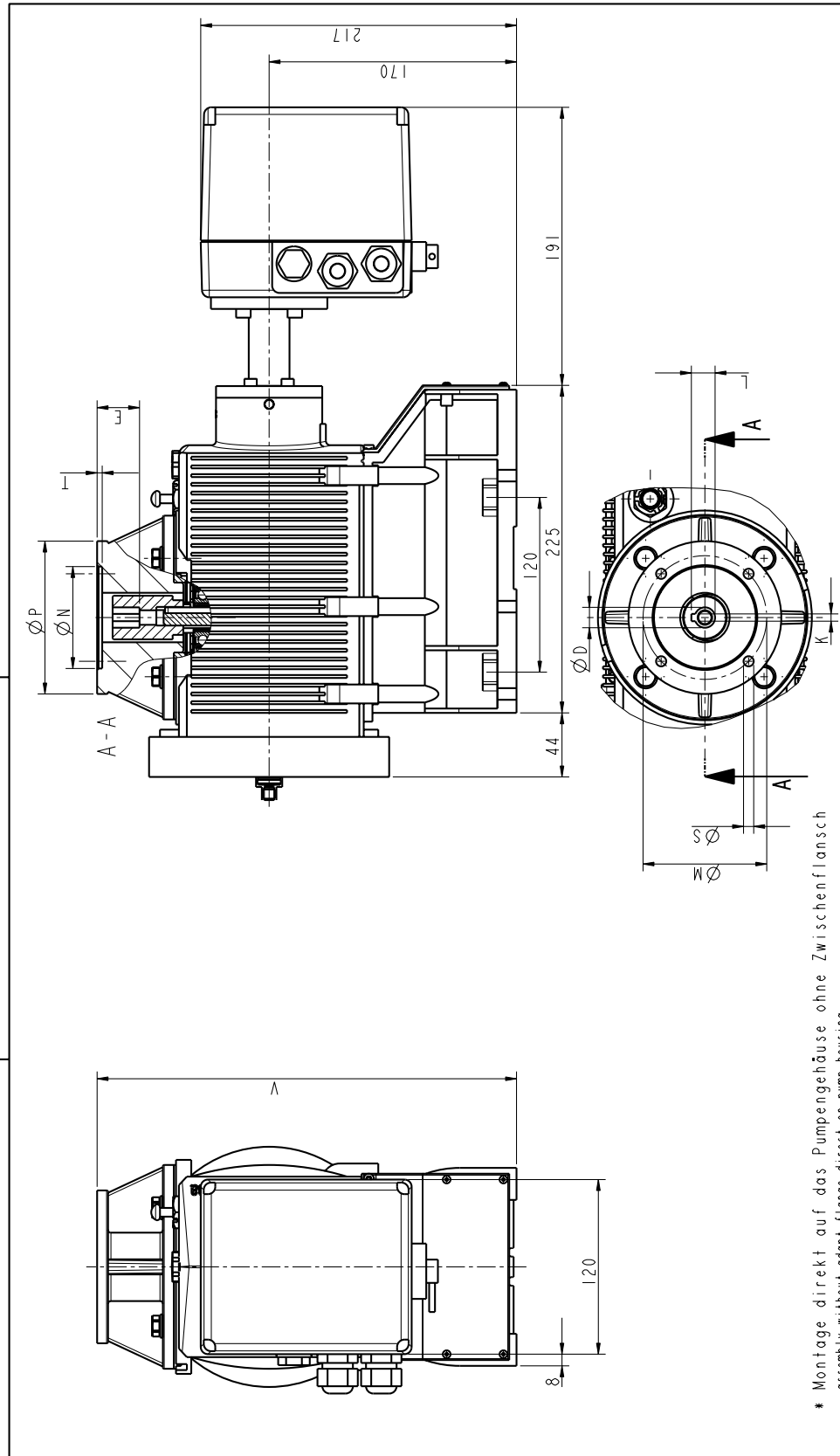

* Montage direkt auf das Pumpengehäuse ohne Zwischenflansch
assembly without adapt flange direct on pump housing

Br. Sz.	Motorflansch motor flange	ØP	ØM	ØN	ØS	ØD	E	T	K	L	V
71	B 14/105	105	85	70	7	14	29	3.5	5	16.3	288
	56 C/138	5.43"	5.88"	4.5"	0.43"	0.62"	1.14"	0.16"	0.2"	0.72"	12.2"
71	B 14/160	160	130	110	9	14	29	6	5	16.3	290
80	B 14/200	200	165	130	11	19	52.5	6	6	21.8	323
63	B 5/140 *	140	115	95	9.5	11	26	3.5	4	12.8	230

Schutzrecht nach DIN34 beachten Copyright reserved

Messstab scale		Oberfl. material		Bereichung/description	
Werkstoff material		Name		Maßblatt S2Ba dimension drawing S2Ba	
Allg. Tol.		Datum		Zehng.-Nr./drawing no.	
Beerb. 31.07.2001		31.07.2001		61_01-101_00_27-73	
Ger. Lubwig		Norm		Blatt	
12 10213-001		14.10.10 Ve		2	
11 09093-008		23.11.08 Ve		3	
10 09093-006		22.10.08 Ve		Bl.	
09 06233		18.06.08 Ba		2	
Zust. Anord.-Nr./-Nr.		Datum		Ers. f. g.l. Z.-Nr. ind. 08 Ers. d.	
10213-001		14.10.10		08	
09093-008		23.11.08		08	
09093-006		22.10.08		08	
06233		18.06.08		08	

17 Motor data sheet standard motor

ProMinent®

Motor Datenblatt / Motor data sheet / Fiche technique pour moteur					
Bestell Nr. order no. / no. de commande		1011036	Hersteller producer / producteur		ATB Mat.Nr.. 376108
Motor- Typ motor type type du moteur	AF63/4C-7	Leistungsfaktor power factor facteur de puissance	0,64 0,66		
Maschinenart type of machine désignation	3 Ph. Motor	Wirkungsgrad efficiency rendement	66% 69%		
Schutzart degree of protection degré de protection	IP55	Bemessungsfrequenz rated frequency fréquence nominale	50 / 60 Hz		
Bauform mounting construction	IMB5	Bemessungsdrehzahl rated speed vitesse nominale	1380 1680	U/min rpm t/mn	
Bemessungsleistung rated output puissance nominale	0,250kW	Wärmeklasse temperature class class d'isolement	F		
Bemessungsspannung rated voltage tension nominale	△ / Δ 380-420/220-240V 380-480/220-280V	Anzugsstrom starting current courant de démarrage	3,5/4,0	fach fold fois	
Bemessungsstrom rated current courant nominale	0,89/1,54A 0,80/1,47A	Anzugsmoment starting torque couple de démarrage	2,3/2,4	fach fold fois	
Geprüft nach tested in acc. with contrôlé selon	EN60034	Kippmoment pull-out torque couple de décrochage	2,4/2,7	fach fold fois	
ATEX Nr.		Umgebungstemperatur ambient temperature température ambiante	40°C		
Ex-Schutzklasse ex-protective system		Schaltung connection branchement	△ / Δ		
		Drehzahlregelbereich speed ajustment range			
Anmerkung comments observation	* auf Anfrage beim Hersteller * upon request at manufacturer * sur demande auprès du producteur				
ProMinent					
Pumpentyp	S2BaHM _____ S ____ S2CaHM _____ U _____ SiBa _____ S ____				
Die Daten entsprechen den Angaben der Motorenhersteller. Kenndaten funktionsgleicher Motoren anderer Hersteller ändern sich nur unwesentlich. Angaben ohne Gewähr. The data correspond to the details given by the motor manufacturers. Ratings of motors with the same functions made by other producers show insignificant changes only. This information is supplied without liability. Les données techniques correspondent au descriptif du fabricant des moteurs. Les données techniques des moteurs similaires chez d' autres fabricants varient très peu. Données sont d' ordre général.					

18 Liquid ends Sigma/ 2

Liquid end Sigma/ 2 130-DN 15 and 350-DN 25 PVT

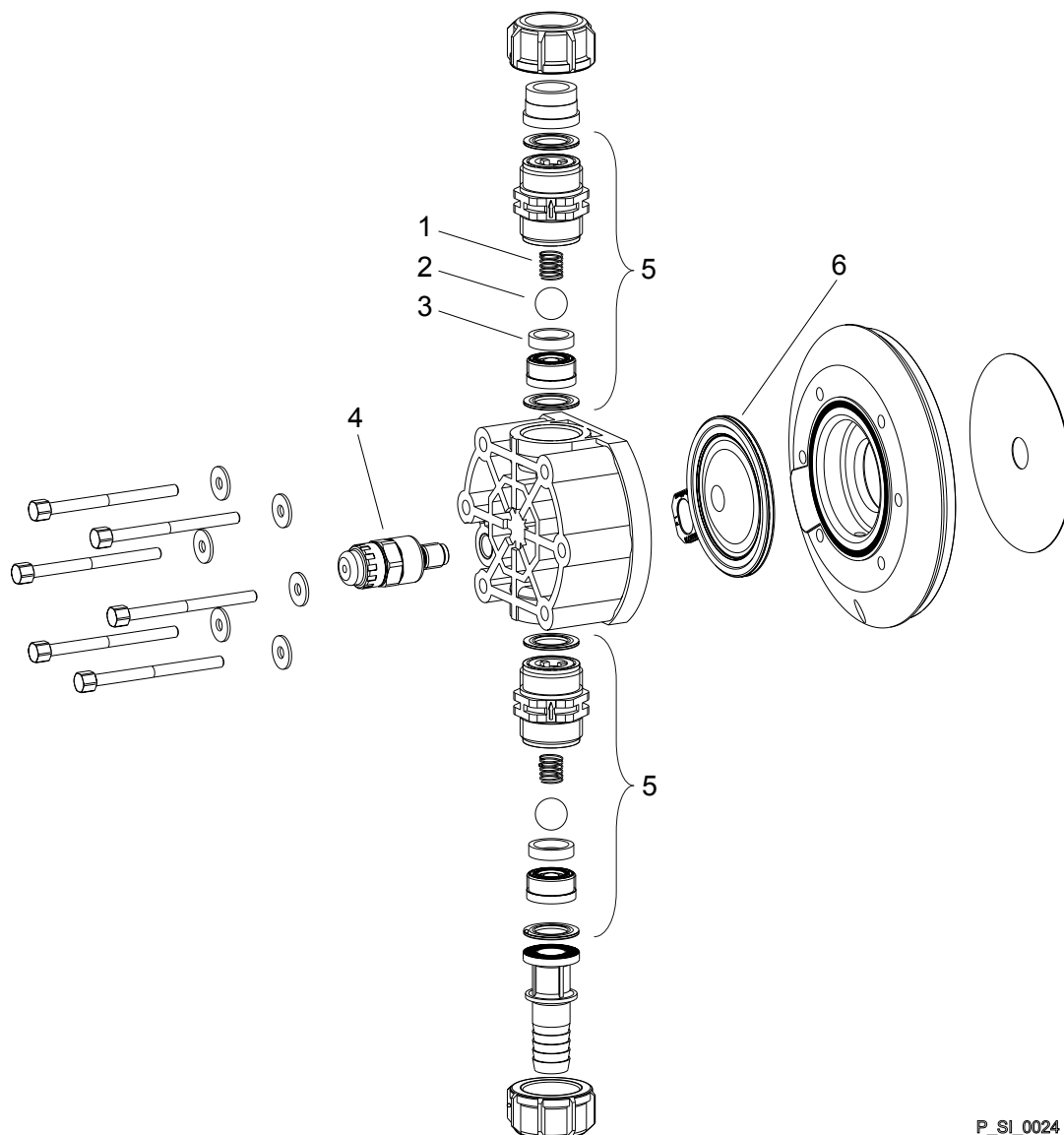

P_SI_0024

Fig. 26: Liquid end Sigma/ 2 130-DN 15 and 350-DN 25 PVT

Item.	Description	Type 16050, 16090, 16130	Type 04350, 07120, 07220
1	Spring	**	**
2	Ball	*	*
3	Ball seat	*	*
4	Diaphragm rupture sensor, visual	1033323	1033323
5	Valve	792517*	740615*
6	Multi-layer diaphragm	1029771*	1033422*

* The items listed are included in the spare parts kit. ** Special accessories (not included in the spare parts kit). Technical changes reserved.

Sigma/ 2 PVA relief valve-A

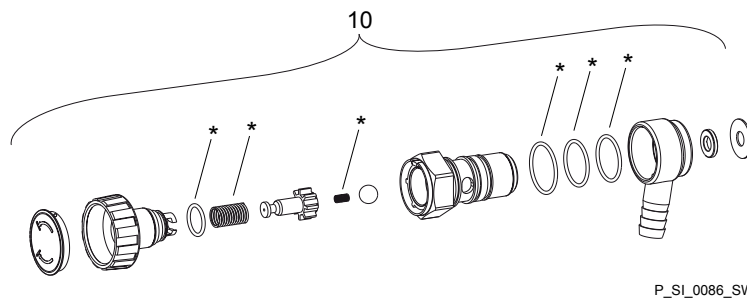
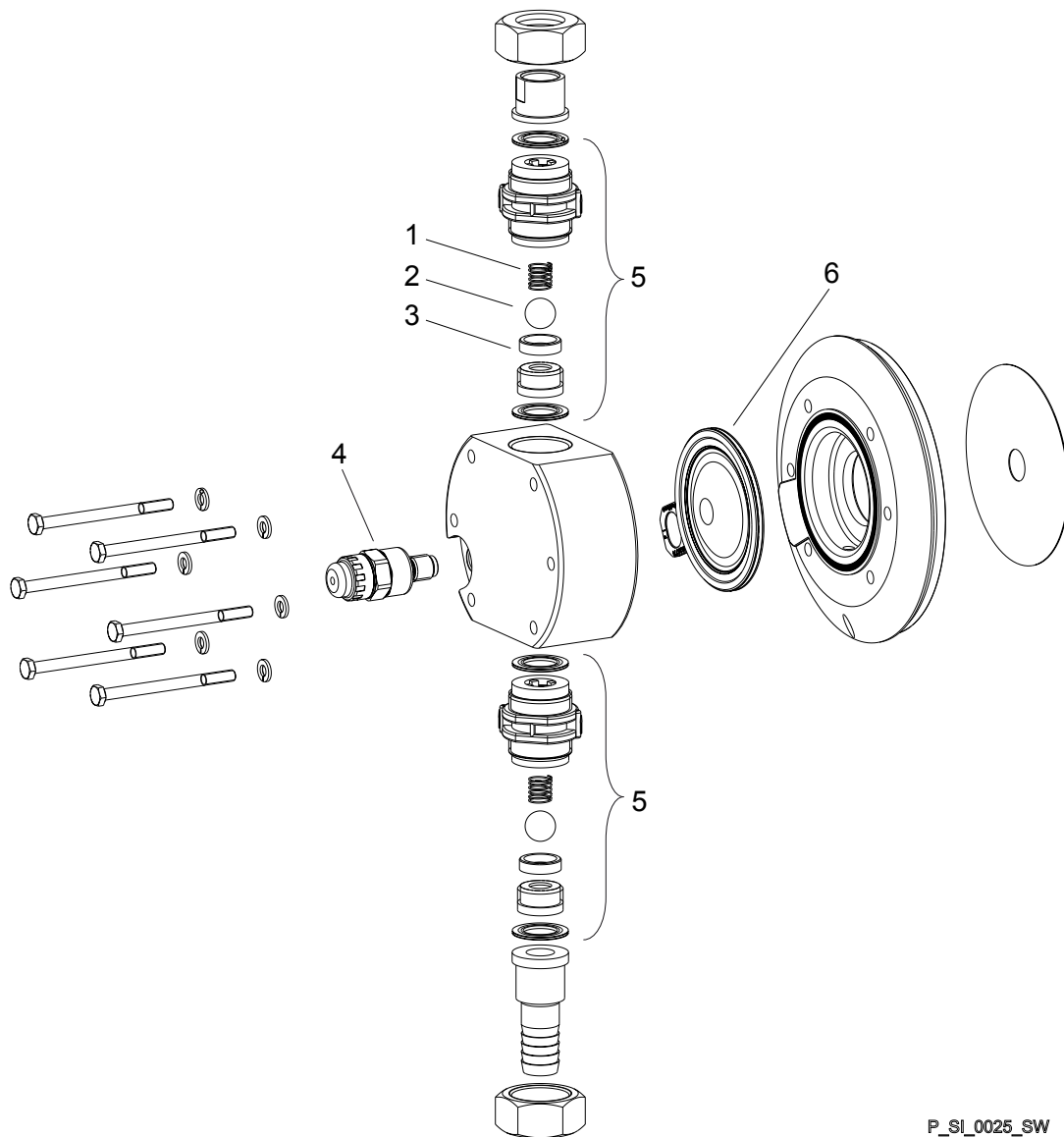

Fig. 27: Sigma/ 2 PVA relief valve-A

Item.	Description	Type 16050, 16090, 16130	Type 07120, 07220	Type 04350,
10	Relief valve, compl. 10 bar PVA	1018947		
10	Relief valve, compl. 7 bar PVA		740811	
10	Relief valve, compl. 4 bar PVA			740812

* The items listed are included in the spare parts kit. Springs made from Hastelloy C, O-rings from FPM-A and EPDM. Technical changes reserved.

Liquid end Sigma/ 2 130 and 350 SST



P_SI_0025_SW

Fig. 28: Liquid end Sigma/ 2 130 and 350 SST

Item.	Description	Type 16050, 16090, 16130	Type 04350, 07120, 07220
1	Spring	*	*
2	Ball	*	*
3	Ball seat	*	*
4	Diaphragm rupture sensor, visual	1033323	1033323
5	Valve	809404	803708
6	Multi-layer diaphragm	1029771*	1033422*

* The items listed are included in the spare parts kit. Technical changes reserved.

Sigma/ 2 SSA relief valve-A

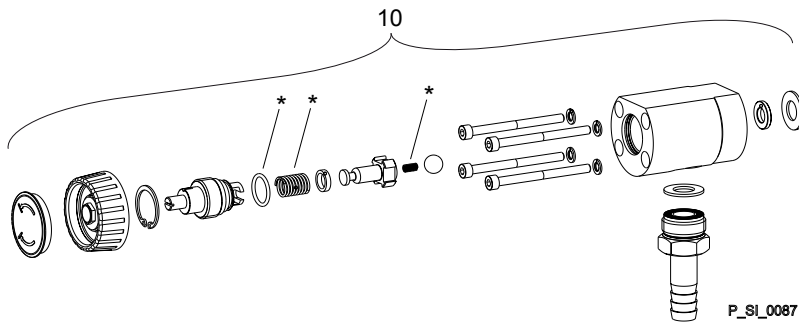

Fig. 29: Sigma/ 2 SSA relief valve-A

Item.	Description	Type 16050, 16090, 16130	Type 07120, 07220	Type 04350,
10	Relief valve, compl. 16 bar SSA	1019246		
10	Relief valve, compl. 7 bar SSA		740815	
10	Relief valve, compl. 4 bar SSA			740814

* The items listed are included in the spare parts kit. Springs made from Hastelloy C, O-rings from FPM-A and EPDM. Technical changes reserved.

19 Wear parts for Sigma/ 2

19.1 Standard

Spare parts kits PVT (liquid ends)

Spare parts kit	Types 16050, 16090, 16130	Types 04350, 07120, 07220
FM 130 - DN15	1035951	
FM 350 - DN25		1035953

Scope of supply: see exploded view drawings.

Spare parts kits SST (liquid ends)

Spare parts kit	Types 16050, 16090, 16130	Types 04350, 07120, 07220
FM 130 - DN15	1035957	
FM 130 - DN15 with 2 complete valves	1035954	
FM 350 - DN25		1035960
FM 350 - DN25 with 2 complete valves		1035959

Scope of supply: see exploded view drawings.

Spare parts kits for integrated relief valve

Spare parts kit	for material version	Seals	Part no.
SPK PRV 4 bar	PVT/SST	FPM-A / EPDM	1031199
SPK PRV 7 bar	PVT/SST	FPM-A / EPDM	1031200
SPK PRV 10 bar	PVT	FPM-A / EPDM	1031201
SPK PRV 16 bar	SST	FPM-A / EPDM	1031203

Scope of supply: see exploded view drawings.

19.2 Physiological safety

Spare parts kits

Scope of supply with PVT material version

1 x Diaphragm, 2 x Suction valve complete, 1 x Discharge valve complete, 1 x Valve balls

1 x Elastomer sealing set (EPDM)

2 x Ball seat housings, 2 x Ball seat discs, 4 x Composite seals

1x Seal washer (for bleed valve or relief valve)

Scope of supply with SST material version

1 x Diaphragm, 2 x Valve balls

2 x Cover rings

4 x Composite seals

1x Seal washer (for bleed valve or relief valve)

Wear parts for Sigma/ 2

Ordering Information

Spare parts kits PVT (liquid ends)

Liquid end	Types 16050, 16090, 16130	Types 07120, 07220, 04350
FM 130 - DN 15	1046472	-
FM 350 - DN 25	-	1046475

Spare parts kits SST (liquid ends)

Liquid end	Types 16050, 16090, 16130	Types 07120, 07220, 04350
FM 130 - DN 15	1046473	-
FM 130 - DN 15 with 2 valves complete	1046474	-
FM 65 - DN 10	-	1046476
FM 65 - DN 10 with 2 valves complete	-	1046477

Wetted materials – "Physiologically safety with regard to wetted materials" design

Material version	Liquid end	Suction / pressure connector	Seals* / ball seat	Balls	Integrated bleed valve or relief valve
PVT	PVDF	PVDF	PTFE / PVDF	Ceramic / glass **	PVDF / EPDM
SST	Stainless steel 1.4404	Stainless steel 1.4581	PTFE / PVDF	Stainless steel 1.4404	Stainless steel / EPDM

* Metering diaphragm is PTFE-coated; seals are PTFE composite seals

PTFE: FDA No. 21 CFR §177.1550

PVDF: FDA No. 21 CFR §177.2510

** with 07120, 07220, 04350

20 EC Declaration of Conformity for Machinery

For pumps without explosion protection:

In accordance with DIRECTIVE 2006/42/EC OF THE EUROPEAN PARLIAMENT AND OF THE COUNCIL, Appendix I, BASIC HEALTH AND SAFETY REQUIREMENTS, section 1.7.4.2. C.

We,

- ProMinent Dosiertechnik GmbH
- Im Schuhmachergewann 5 - 11
- D - 69123 Heidelberg,

hereby declares that the product specified in the following, complies with the relevant basic health and safety requirements of the EC Directive, on the basis of its functional concept and design and in the version distributed by us.

This declaration loses its validity in the event of a modification to the product not agreed with us.

Designation of the product:	Metering pump, Sigma product range
Product type:	S2Ba...
Serial number:	refer to nameplate on the device
Relevant EC directives:	EC Machinery Directive (2006/42/EC) EC EMC Directive (2004/108/EC) Compliance with the protection targets of the Low Voltage Directive (2006/95/EC) according to Appendix I, No. 1.5.1 of the Machinery Directive 2006/42/EC
Harmonised standards applied, in particular:	EN ISO 12100 EN 809 EN 61010-1 EN 61000-6-2/3

Date: 20/09/2013

21 EC Declaration of Conformity for Machinery Used in Areas at Risk of Explosion

For pumps with explosion protection:

We,

- ProMinent Dosiertechnik GmbH
- Im Schuhmachergewann 5 - 11
- DE - 69123 Heidelberg,

hereby declares that the product specified in the following, complies with the relevant basic health and safety requirements of the EC Directive, on the basis of its functional concept and design and in the version distributed by us.

This declaration loses its validity in the event of a modification to the product not agreed with us.

Designation of the product:	Metering pump, Sigma 2 product range. Version "Explosion protection" in accordance with "ATEX 95"
Product type:	S2Ba_____XY__ Characteristic value "X" = "P" or "L", and characteristic value Y = "1" or "2" or "X" = "1, 2, 3, 4 or 5" and "Y" = "A"
Serial number:	refer to nameplate on the device
Relevant EC directives:	EC Machinery Directive (2006/42/EC) EC EMC Directive (2004/108/EC) EC Explosion Prevention Directive (94/9/EC)
Harmonised standards applied, in particular:	Pump without motor: EN ISO 12100-1/2, EN 809, EN 13463-1/5 Motor Ex "e": EN 50014, EN 50019 Motor Ex "d": EN 60079-0, EN 60079-1, EN 60079-7, EN 61241-0, EN 61241-1 Stroke sensor: EN 60079-0, EN 60079-11, EN 60079-26
The combination of the components does not give rise to any new Ex-related dangers	
Ex-designations:	Pump without motor: II 2G c IIC T4 X Motor (characteristic value "Y"="1") : II 2G EEx e IIC T3 Motor (characteristic value "Y"="2") : II 2G EEx de IIC T4 Diaphragm rupture sensor: II 1G Ex ia IIC T6
	Overall system: II 2G c IIC T3 X (for "Y"="1") or II 2G c IIC T4 X (for "Y"="2" or "A")

Date: 26/05/2010



ProMinent Dosiertechnik GmbH
Im Schuhmachergewann 5-11
69123 Heidelberg
Germany
Telephone: +49 6221 842-0
Fax: +49 6221 842-612
email: info@prominent.com
Internet: www.prominent.com

986271, 2, en_GB